**UNITED STATES
SECURITIES AND EXCHANGE COMMISSION
WASHINGTON, D.C. 20549**

FORM 10-K

ANNUAL REPORT PURSUANT TO SECTION 13 OR 15(d) OF THE SECURITIES EXCHANGE ACT OF 1934

For the Fiscal Year Ended December 31, 2014

OR

TRANSITION REPORT PURSUANT TO SECTION 13 OR 15(d) OF THE SECURITIES EXCHANGE ACT OF 1934

Commission File No. 001-35456

ALLISON TRANSMISSION HOLDINGS, INC.

(Exact Name of Registrant as Specified in Its Charter)

Delaware
(State of Incorporation)

26-0414014
(I.R.S. Employer
Identification Number)



One Allison Way
Indianapolis, IN 46222
(Address of Principal Executive Offices and Zip Code)

(317) 242-5000
(Registrant's Telephone Number, Including Area Code)

Securities registered pursuant to Section 12(b) of the Act:

<u>Title of each class</u>	<u>Name of each exchange on which registered</u>
Common Stock, \$0.01 par value	New York Stock Exchange

Securities registered pursuant to Section 12(g) of the Act: None

Indicate by check mark if the registrant is a well-known seasoned issuer, as defined in Rule 405 of the Securities Act. Yes No

Indicate by check mark if the registrant is not required to file reports pursuant to Section 13 or Section 15(d) of the Act. Yes No

Indicate by check mark whether the registrant (1) has filed all reports required to be filed by Section 13 or 15(d) of the Securities Exchange Act of 1934 during the preceding 12 months (or for such shorter period that the registrant was required to file such reports), and (2) has been subject to such filing requirements for the past 90 days. Yes No

Indicate by check mark whether the registrant has submitted electronically and posted on its corporate Web site, if any, every Interactive Data File required to be submitted and posted pursuant to Rule 405 of Regulation S-T (232.405 of this chapter) during the preceding 12 months (or for such shorter period that the registrant was required to submit and post such files). Yes No

Indicate by check mark if disclosure of delinquent filers pursuant to Item 405 of Regulation S-K is not contained herein, and will not be contained, to the best of registrant's knowledge, in definitive proxy or information statements incorporated by reference in Part III of this Form 10-K or any amendment to this Form 10-K.

Indicate by check mark whether the registrant is a large accelerated filer, an accelerated filer, a non-accelerated filer, or a smaller reporting company. See definitions of "large accelerated filer," "accelerated filer," and "smaller reporting company" in Rule 12b-2 of the Exchange Act.

Large accelerated filer Accelerated filer

Non-accelerated filer (Do not check if a smaller reporting company) Smaller reporting company

Indicate by check mark whether the registrant is a shell company (as defined in Rule 12b-2 of the Exchange Act). Yes No

The aggregate market value of the voting and non-voting stock held by non-affiliates was approximately \$5,148.6 million as of June 30, 2014.

As of February 5, 2015, there were 180,053,650 shares of Common Stock outstanding.

Documents Incorporated by Reference

Portions of the Registrant's definitive Proxy Statement for its 2015 annual meeting of stockholders will be incorporated by reference in Part III of this Annual Report on Form 10-K.

Table of Contents

INDEX

	<u>Page</u>
<u>PART I.</u>	
<u>Item 1.</u> Business	3-14
<u>Item 1A.</u> Risk Factors	15-26
<u>Item 1B.</u> Unresolved Staff Comments	27
<u>Item 2.</u> Properties	27
<u>Item 3.</u> Legal Proceedings	27
<u>Item 4.</u> Mine Safety Disclosures	27
<u>PART II.</u>	
<u>Item 5.</u> Market for Registrant’s Common Equity, Related Stockholder Matters and Issuer Purchases of Equity Securities	28-29
<u>Item 6.</u> Selected Financial Data	30
<u>Item 7.</u> Management’s Discussion and Analysis of Financial Condition and Results of Operations	31-41
<u>Item 7A.</u> Quantitative and Qualitative Disclosures About Market Risk	42-43
<u>Item 8.</u> Financial Statements and Supplementary Data	44-84
<u>Item 9.</u> Changes in and Disagreements With Accountants on Accounting and Financial Disclosure	85
<u>Item 9A.</u> Controls and Procedures	85
<u>Item 9B.</u> Other Information	85
<u>PART III.</u>	
<u>Item 10.</u> Directors, Executive Officers and Corporate Governance	86
<u>Item 11.</u> Executive Compensation	86
<u>Item 12.</u> Security Ownership of Certain Beneficial Owners and Management and Related Stockholder Matters	86
<u>Item 13.</u> Certain Relationships and Related Transactions, and Director Independence	86
<u>Item 14.</u> Principal Accounting Fees and Services	86
<u>PART IV.</u>	
<u>Item 15.</u> Exhibits, Financial Statement Schedules	87-90

Cautionary Note Regarding Forward-Looking Statements

This Annual Report on Form 10-K contains forward-looking statements. The words “believe,” “expect,” “anticipate,” “intend,” “estimate” and other expressions that are predictions of or indicate future events and trends and that do not relate to historical matters identify forward-looking statements. You should not place undue reliance on these forward-looking statements. Although forward-looking statements reflect management’s good faith beliefs, reliance should not be placed on forward-looking statements because they involve known and unknown risks, uncertainties and other factors, which may cause the actual results, performance or achievements to differ materially from anticipated future results, performance or achievements expressed or implied by such forward-looking statements. Forward-looking statements speak only as of the date the statements are made. We undertake no obligation to publicly update or revise any forward-looking statement, whether as a result of new information, future events, changed circumstances or otherwise. These forward-looking statements are subject to numerous risks and uncertainties, including, but not limited to: our participation in markets that are competitive; general economic and industry conditions; our ability to prepare for, respond to and successfully achieve our objectives relating to technological and market developments and changing customer needs; the failure of markets outside North America to increase adoption of fully-automatic transmissions; risks related to our substantial indebtedness; the discovery of defects in our products, resulting in delays in new model launches, recall campaigns and/or increased warranty costs and reduction in future sales or damage to our brand and reputation; the concentration of our net sales in our top five customers and the loss of any one of these; risks associated with our international operations; brand and reputational risks; our intention to pay dividends and repurchase shares of our common stock; and labor strikes, work stoppages or similar labor disputes, which could significantly disrupt our operations or those of our principal customers.

Important factors that could cause actual results to differ materially from our expectations are disclosed under Part I, Item 1A, “Risk Factors” in this Annual Report on Form 10-K. All written and oral forward-looking statements attributable to us, or persons acting on our behalf, are expressly qualified in their entirety by the cautionary statements as well as other cautionary statements that are made from time to time in our other Securities and Exchange Commission filings or public communications. You should evaluate all forward-looking statements made in this Annual Report on Form 10-K in the context of these risks and uncertainties.

Certain Trademarks

This Annual Report on Form 10-K includes trademarks, such as Allison Transmission and ReTran, which are protected under applicable intellectual property laws and are our property and/or the property of our subsidiaries. This report also contains trademarks, service marks, copyrights and trade names of other companies, which are the property of their respective owners. We do not intend our use or display of other companies’ trademarks, service marks, copyrights or trade names to imply a relationship with, or endorsement or sponsorship of us by, any other companies. Solely for convenience, our trademarks and trade names referred to in this report may appear without the ® or ™ symbols, but such references are not intended to indicate, in any way, that we will not assert, to the fullest extent under applicable law, our rights or the right of the applicable licensor to these trademarks and trade names.

PART I.

ITEM 1. Business

Overview

Allison Transmission Holdings, Inc. and its subsidiaries (“Allison,” the “Company” or “we”) design and manufacture commercial and defense fully-automatic transmissions. The business was founded in 1915 and has been headquartered in Indianapolis, Indiana since inception. Allison was an operating unit of General Motors Corporation (“Old GM”) from 1929 until 2007, when Allison once again became a stand-alone company. In March 2012, Allison began trading on the New York Stock Exchange under the symbol, “ALSN”.

We have approximately 2,700 employees and 13 different transmission product lines. Although approximately 80% percent of revenues were generated in North America in 2014, we have a global presence by serving customers in Europe, Asia, South America and Africa. We serve customers through an independent network of approximately 1,400 independent distributor and dealer locations worldwide.

Our Business

We are the world’s largest manufacturer of fully-automatic transmissions for medium- and heavy-duty commercial vehicles and medium- and heavy-tactical U.S. defense vehicles. Allison transmissions are used in a wide variety of applications, including on-highway trucks (distribution, refuse, construction, fire and emergency), buses (primarily school, transit and hybrid-transit), motorhomes, off-highway vehicles and equipment (primarily energy, mining and construction) and defense vehicles (wheeled and tracked). We estimate that globally, in 2014, we sold approximately 63% of all fully-automatic transmissions for medium- and heavy-duty on-highway commercial vehicle applications. We believe the Allison brand is one of the most recognized in our industry as a result of the performance, reliability and fuel efficiency of our transmissions and is associated with high quality, durability, vocational value, technological leadership and superior customer service.

We introduced the world’s first fully-automatic transmission for commercial vehicles over 60 years ago. Since that time, we have driven the trend in North America and Western Europe towards increasing automaticity by targeting a diverse range of commercial vehicle vocations. Allison transmissions are optimized for the unique performance requirements of end users, which typically vary by vocation. Our products are highly engineered, requiring advanced manufacturing processes, and employ complex software algorithms for our transmission controls to maximize end user performance. We have developed over 100 different models that are used in more than 2,500 different vehicle configurations and are compatible with more than 500 combinations of engine brands, models and ratings (including diesel, gasoline, natural gas and other alternative fuels). In 2014, over 7,500 unique Allison-developed calibrations were used with our transmission control modules.

Our Industry

Commercial vehicles typically employ one of three transmission types: manual, automated manual transmissions (“AMT”) or fully-automatic. Manual transmissions are the most prevalent transmission type used in Class 8 tractors in North America and in medium- and heavy-duty commercial vehicles, generally, outside North America. Manual transmissions utilize a disconnect clutch causing power to be interrupted during each gear shift resulting in energy loss-related inefficiencies and less work being accomplished for a given amount of fuel consumed. In long-distance trucking, this power interruption is not a significant factor, as the manual transmission provides its highest degree of fuel economy during steady-state cruising. However, steady-state cruising is only one part of the duty cycle. When the duty cycle requires a high degree of “start and stop” activity or speed transients, as is common in many vocations as well as in urban environments, we believe manual transmissions result in reduced performance, lower fuel efficiency, lower average speed for a given amount of fuel consumed and inferior ride quality. Moreover, the clutches must be replaced regularly, resulting in increased maintenance expense and vehicle downtime. Manual transmissions also require a skilled driver to operate the disconnect clutch when launching the vehicle and shifting gears. AMTs are manual transmissions that feature automated operation of the disconnect clutch. Fully-automatic transmissions utilize technology that smoothly shifts gears instead of a disconnect clutch, thereby delivering uninterrupted power to the wheels during gear shifts and requiring minimal driver input. These transmissions deliver superior acceleration, higher productivity, increased fuel efficiency, reduced operating costs, less driveline shock and smoother shifting relative to both manual transmissions and AMTs in vocations with a high degree of “start and stop” activity, as well as in urban environments.

[Table of Contents](#)

Fuel efficiency, reduction in fuel consumption and greenhouse gas emissions are important considerations for commercial vehicles everywhere and they tend to go together. We believe fuel efficiency, the measure of work performed for a given amount of fuel consumed, is the best method to assess fuel consumption of commercial vehicles as compared to the more commonly-used fuel economy metric of miles-per-gallon (“MPG”). MPG is inadequate for commercial vehicles because it does not encompass two key elements of efficiency that we believe are important to vehicle owners and operators: payload and transport time. For example, if more work can be completed or more payload hauled using the same amount of fuel and/or over a shorter period of time, then we believe the vehicle is more fuel efficient. Since fuel economy and its MPG metric only accounts for distance traveled and fuel consumed, ignoring time and work performed, it is therefore an inferior metric to fuel efficiency when it comes to assessing commercial vehicles. Markets, regulations, policies and technology continue to evaluate these topics.

Our Served Markets

We sell our transmissions globally for use in medium- and heavy-duty on-highway commercial vehicles, off-highway vehicles and equipment and defense vehicles. In addition to the sale of transmissions, we also sell branded replacement parts, support equipment and other products necessary to service the installed base of vehicles utilizing our transmissions. The following table provides a summary of our business by end market, for the fiscal year ended December 31, 2014.

END MARKET	NORTH AMERICA			OUTSIDE NORTH AMERICA		DEFENSE	SERVICE PARTS, SUPPORT EQUIPMENT & OTHER
	ON-HIGHWAY	HYBRID TRANSIT BUS	OFF-HIGHWAY	ON-HIGHWAY	OFF-HIGHWAY		
2014 NET SALES (IN MILLIONS)	\$988	\$93	\$100	\$264	\$81	\$157	\$444
% OF TOTAL	47%	4%	5%	12%	4%	7%	21%
MARKET POSITION	<ul style="list-style-type: none"> #1 supplier of fully-automatic transmissions 	<ul style="list-style-type: none"> A leading supplier of hybrid-propulsion systems 	<ul style="list-style-type: none"> A leading independent supplier 	<ul style="list-style-type: none"> #1 supplier of fully-automatic transmissions in China and India Established presence in Western Europe 	<ul style="list-style-type: none"> A leading independent supplier 	<ul style="list-style-type: none"> #1 supplier of transmissions for the U.S. Department of Defense 	<ul style="list-style-type: none"> Approximately 1,400 dealers and distributors worldwide
VOCATIONS OR END USE	<ul style="list-style-type: none"> Distribution Emergency Refuse Construction Utility School, transit, shuttle and coach buses Motorhome Metro tractors 	<ul style="list-style-type: none"> Hybrid transit bus Hybrid shuttle bus 	<ul style="list-style-type: none"> Energy Mining Construction Specialty vehicle 	<ul style="list-style-type: none"> Distribution Emergency Refuse Construction Utility Transit, shuttle and coach buses 	<ul style="list-style-type: none"> Energy Mining Construction Specialty vehicle 	<ul style="list-style-type: none"> Medium- and heavy-tactical wheeled platforms Tracked combat platforms 	<ul style="list-style-type: none"> Parts Support equipment Remanufactured transmissions Fluids

Refer to NOTE 18, “Concentration of Risk” and NOTE 22, “Geographic Information” in Part II, Item 8, of this Annual Report on Form 10-K for additional information on our significant original equipment manufacturer (“OEM”) customers and net sales by geographical areas.

North America

On-Highway.

We are the largest manufacturer of fully-automatic transmissions for the on-highway medium- and heavy-duty commercial vehicle market in North America. The following is a summary of our on-highway net sales by vehicle class in North America.

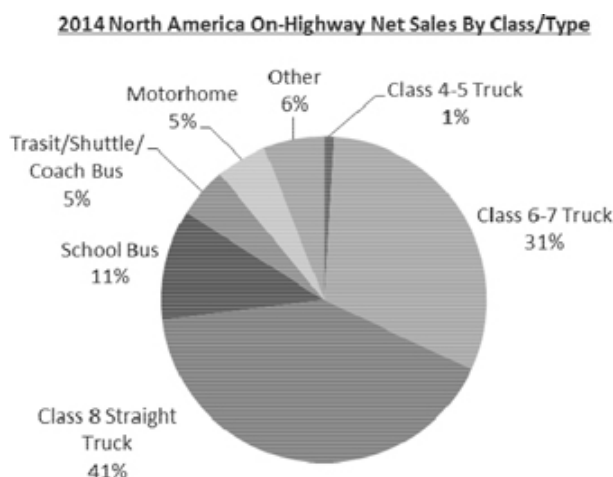

Our core North American on-highway market includes Class 4-5, Class 6-7 and Class 8 straight trucks, conventional transit, shuttle and coach buses, school buses and motorhomes. Class 8 trucks are subdivided into two markets: straight and tractor. Class 8 straight trucks are those with a unified body (e.g., refuse, construction, and dump trucks), while tractors have a vehicle chassis that is separable from the trailer they pull. We have been supplying transmissions for Class 8 straight trucks for decades, and it is a core end market for us. Today, we have very limited exposure to the Class 8 tractor market because lower priced manual transmissions generally meet the needs of these vehicles which are primarily used in long distance hauling. However, we have identified a portion of the Class 8 tractor market that we call metro tractors that are used in urban environments the majority of the time. During 2013, we began production of a fully-automatic transmission (the “TC10”) that meets the unique duty cycle requirements of the Class 8 metro tractor market. Combining the startability and continuous, uninterrupted power qualities of a fully-automatic transmission with the cruising aspects of a manual transmission, the TC10 offers an alternative to traditional manual and automated manual transmissions in tractor applications.

We sell substantially all of our transmissions in the North American on-highway market to OEMs. These OEMs, in turn, install our transmissions in vehicles in which our transmission is either the exclusive transmission available or is specifically requested by end users who are choosing between a manual transmission, an AMT or a fully-automatic transmission. OEM customers representing approximately 90% of our 2014 North American on-highway unit volume participate in long-term supply agreements (“LTSA”) with us. Generally, these supply agreements offer the OEM customer defined levels of mutual commitment with respect to growing Allison’s presence in the OEMs’ products and promotional efforts, pricing and sharing of commodity cost risk. The length of our customer agreements is typically between four and five years. We often compete in this market against independent manufacturers of manual transmissions, AMTs, fully-automatic transmissions manufactured by Ford Motor Company (“Ford”), ZF Friedrichshafen AG (“ZF”) and Voith GmbH (“Voith”), and against OEMs in certain weight classes that use their own internally manufactured transmissions in certain vehicles.

The following table presents a summary of our competitive position by vehicle class in the North America on-highway end market.

	CLASS 4-5 TRUCKS	CLASS 6-7 TRUCKS	CLASS 8 STRAIGHT TRUCKS	SCHOOL BUSES	MOTORHOMES
2014 SHARE	5%	74%	57%	95%	46%
PRIMARY COMPETITION	<ul style="list-style-type: none"> Ford 	<ul style="list-style-type: none"> Manual Transmissions AMTs Ford 	<ul style="list-style-type: none"> Manual Transmissions AMTs 	<ul style="list-style-type: none"> Ford Voith ZF 	<ul style="list-style-type: none"> Ford

Hybrid Transit Buses.

The interest in conserving fuel and reducing greenhouse gas emissions is driving demand for more fuel efficient commercial vehicles. In North America, we sold approximately 73% of all units for the hybrid transit bus market in 2014. Our customers in this North American end market are typically city, state and federal governmental entities, which utilize government funds to subsidize a portion of the purchase price for the transit buses containing our hybrid-propulsion system. In this market, we compete primarily with BAE Systems plc (“BAE”).

Off-Highway.

We have provided products used in vehicles and equipment that serve energy, mining and construction applications in North America for over 50 years. Off-highway energy applications include hydraulic fracturing equipment, well-stimulation equipment, pumping equipment, and well-servicing rigs, which often use a fully-automatic transmission to propel the vehicle and drive auxiliary equipment. We maintain a leadership position in this end market, with nearly all producers of well-stimulation and well-servicing equipment utilizing our heavy duty off-highway transmissions. Additionally, we sell kits that can increase the horsepower of existing off-highway products. Competition includes Caterpillar, Inc. (“Caterpillar”) and Twin Disc, Inc. (“Twin Disc”).

We also provide heavy-duty transmissions used in mining trucks, specialty vehicles and construction vehicles. Mining applications include trucks used to haul various commodities and other products, including rigid dump trucks, underground trucks and long-haul tractor trailer trucks with load capacities between 40 to 110 tons. Our major competitors in this end market are Caterpillar and Komatsu, Ltd. (“Komatsu”), both of which are vertically integrated and manufacture fully-automatic transmissions for their own vehicles. Specialty vehicles using our heavy-duty transmissions include airport rescue and firefighting vehicles and heavy-equipment transporters. Construction applications include articulated dump trucks with Caterpillar, Volvo and ZF as competitors.

Outside North America

Outside North America we serve several different markets, including: Europe, Middle East, Africa (“EMEA”), Asia-Pacific, South America and India.

On-Highway.

We are the largest manufacturer of fully-automatic transmissions for the commercial vehicle market outside of North America. While the use of fully-automatic transmissions in the medium- and heavy-duty commercial vehicle market has been widely accepted in North America, the markets outside North America continue to be dominated by manual transmissions. In 2014, fully-automatic transmission-equipped medium- and heavy-duty commercial vehicles represented less than 5% of the vehicles in markets outside North America and are concentrated in certain vocational end markets. The following is a summary of our on-highway net sales by region outside of North America.

2014 Outside North America On-Highway Net Sales By Region

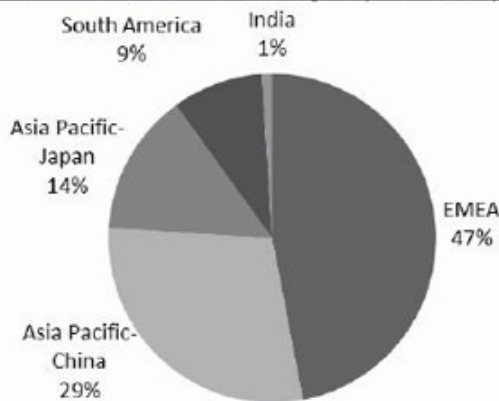

Europe, Middle East, Africa. EMEA is composed of several different markets, each of which differs significantly from our core North American market by the degree of market maturity, sophistication and acceptance of fully-automatic transmission technology. Within Europe, we serve Western European developed markets, as well as Russian and Eastern European emerging markets, principally in the refuse, emergency, bus, coach, distribution and utility markets. Competition in Western Europe is most notably characterized by a high level of vertical powertrain integration with OEMs often utilizing their own manual transmissions and AMTs in their vehicles. The Middle East and Africa regions are generally characterized by very limited local vehicle production, with imports from the U.S., South America, Turkey, China, India and Europe accounting for the majority of vehicles.

[Table of Contents](#)

Asia-Pacific. Our key Asia-Pacific markets include China, Japan, Australia, and South Korea; however, we actively participate in several other important Asia-Pacific countries including Taiwan, Indonesia, Malaysia and Thailand, which are primarily importers of commercial vehicles. Within Asia-Pacific, our sales efforts are principally focused on the transit bus and vocational truck markets. Currently, manual transmissions are the predominant transmissions used in commercial vehicles in the Asia-Pacific region.

South America. The South American region is characterized by a high level of OEM integration, with captive manual transmission and AMT manufacturing. Currently, manual transmissions are the predominant transmissions used in commercial vehicles in South America.

India. Currently, manual transmissions are the predominant transmission used in commercial vehicles in India.

Off-Highway.

The following is a summary of our off-highway net sales by region outside of North America.

2014 Outside North America Off-Highway Net Sales By Region

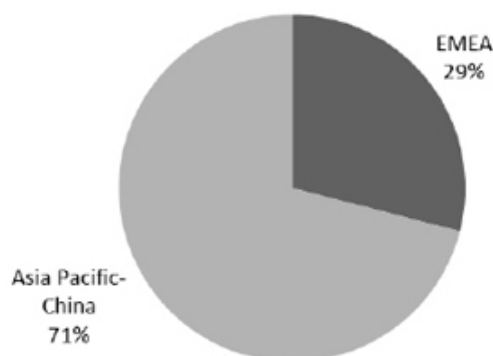

Europe, Middle East, Africa. Our off-highway markets in EMEA are mining and construction. Our major off-highway competitors are Caterpillar and Komatsu, both of which are vertically integrated manufacturers of off-highway mining vehicles, including the specific fully-automatic transmission used in their mining trucks. A typical construction application is the articulated dump truck, with competition from Caterpillar, Volvo and ZF transmissions.

Asia-Pacific. Off-highway markets in Asia are shared by energy, mining and construction applications. Our primary competitors are Caterpillar, Danyang Winstar Auto Parts Co. and Twin Disc in energy applications, Caterpillar and Komatsu in mining applications and Caterpillar, Volvo and ZF in construction applications.

Defense

We have a long-standing relationship with the U.S. Department of Defense (“DOD”), dating back to 1946, when we began developing our first-generation tank transmission. Today, we sell substantially all of the transmissions for medium- and heavy-tactical wheeled vehicle platforms including the Family of Medium Tactical Vehicles, Armored Security Vehicles, Heavy Expanded Mobility Tactical Trucks, Heavy Equipment Transporters, Palletized Loading Systems, M915 Series Trucks, Medium Tactical Vehicle Replacements and the Logistic Vehicle System Replacement. Additionally, we supplied transmissions for the majority of Mine-Resistant Ambush Protected (“MRAP”) Vehicles and the MRAP All-Terrain Vehicle and for all three potential manufacturers of the Joint Light Tactical Vehicles. Transmissions for our wheeled vehicle platforms are typically sold to OEMs.

We are also the supplier on two of the three key tracked vehicle platforms, the Abrams tank and the M113 family of vehicles, which are sold directly to the DOD. Additionally, we sell parts kits to licensees for the production of transmissions for tracked vehicles manufactured outside North America. Overall, we have seen the demand for U.S. defense vehicles decrease as the funding for defense vehicles declines. Additionally, the DOD budgets and supplemental spending have allowed them to recapitalize and reset many vehicle systems, which has reduced the average age of the fleet and the need to procure new vehicles.

Globally, we face competition for the supply of our transmissions in tracked defense vehicles primarily from L-3 Communications Corporation, Renk AG and ZF. Additionally, we face limited competition from Caterpillar in certain defense wheeled vehicle platforms.

Service Parts, Support Equipment and Other





The aftermarket provides us with a relatively stable source of revenues as the installed base of vehicles and equipment utilizing our transmissions continues to grow. The need for replacement parts is driven by normal vehicle and equipment maintenance requirements and is not significantly impacted by economic cycles. Uninterrupted operation is generally critical for end users' profitability. End users focus on getting the vehicle back in service, which in some cases results in the aftermarket purchase decision being less price-sensitive.





The sale of Allison-branded parts and fluids, remanufactured transmissions and support equipment is fundamental to our brand promise. We have assembled a worldwide network of approximately 1,400 independent distributor and dealer locations to sell, service and support our transmissions. As part of our brand strategy, our distributors and dealers are required to sell genuine Allison-branded parts. Within the aftermarket, we offer remanufactured transmissions under our ReTran brand, which provides a cost-effective alternative for transmission repairs and replacements. We also provide support equipment to our OEMs to assist in installing new Allison transmissions into vehicles, and, therefore, sales of support equipment are dependent upon sales of new transmissions.



Over the last few years, traditional aftermarket sales have been tempered by improvements in product quality and durability. While traditional aftermarket sales are expected to grow, support equipment sales fluctuate with the introduction of new transmissions. The competition for service parts and ReTran transmissions comes from a variety of smaller-scale companies sourcing non-genuine "will-fit" parts from unauthorized manufacturers. These "will-fit" parts often do not meet our product specifications, and therefore may be of lesser quality than genuine Allison parts.

Our Product Offerings

Allison transmissions are sold under the Allison Transmission brand name and remanufactured transmissions are sold under the ReTran brand name. The following is a summary of our 13 transmission product lines.

<i>On-Highway Products</i>		
Product	Applications	
1000/2000 	<ul style="list-style-type: none"> ▪ Distribution ▪ Motorhome ▪ Services 	<ul style="list-style-type: none"> ▪ Refuse ▪ School/Shuttle Bus ▪ Wheeled Military ▪ Specialty
3000 	<ul style="list-style-type: none"> ▪ Construction ▪ Distribution ▪ Fire and Emergency ▪ Motorhome ▪ Wheeled Military 	<ul style="list-style-type: none"> ▪ Coach and Transit Bus ▪ Refuse ▪ Specialty ▪ Services
4000 	<ul style="list-style-type: none"> ▪ Construction ▪ Distribution ▪ Fire and Emergency ▪ Motorhome ▪ Wheeled Military 	<ul style="list-style-type: none"> ▪ Coach and Transit Bus ▪ Refuse ▪ Specialty ▪ Articulated dump truck ▪ Well Service Rigs
TC 10 	<ul style="list-style-type: none"> ▪ Metro Tractors 	
H 40/50 EP 	<ul style="list-style-type: none"> ▪ Hybrid Transit Bus 	

<i>Off-Highway Products</i>		
Product		Applications
5000	6000	<ul style="list-style-type: none"> ▪ Underground Mine Truck ▪ Rigid Dump Truck ▪ Well Service Rigs
		
8000	9000	<ul style="list-style-type: none"> ▪ Rigid Dump Truck ▪ Hydraulic fracturing equipment
		

<i>Tracked Defense Products</i>		
Product		Applications
X1100		<ul style="list-style-type: none"> ▪ Tracked Defense (Abrams)
X200		<ul style="list-style-type: none"> ▪ Tracked Defense (M113 Family of Vehicles)

In addition to our current product offerings, we have other products and technologies under development, including hybrid-propulsion systems designed for use in medium- and heavy-duty commercial trucks and buses, higher horsepower fracturing transmissions for use in off-highway applications and fuel efficiency options for our on-highway products. During 2014, we recorded an impairment loss related to certain long-lived assets associated with the production of the H3000 and H4000 hybrid-propulsion systems. See NOTE 2 of Notes to Consolidated Financial Statements included in Part II, Item 8 of this Annual Report on Form 10-K for additional details.

Product Development and Engineering

We maintain product development and engineering capability dedicated to the design, development, refinement and support of our fully-automatic transmissions and hybrid-propulsion systems. We believe our customers expect our products to provide unparalleled performance and value defined in various ways, including delivering maximum cargo in minimum time, using the least amount of fuel possible while employing the fewest vehicles possible and experiencing maximum vehicle uptime. In response to those needs and the evolving customer focus on fuel efficiency, we provide vehicle specification guidelines, transmission control software and mechanical components to optimize fuel economy while delivering desired vehicle performance. Further, we are developing new technology and products to improve fuel efficiency and fuel economy by allowing engines to operate more efficiently and at lower speeds to avoid consuming fuel without compromising performance. Building on our engineering capabilities, we pioneered hybrid-propulsion in commercial vehicles and are developing new hybrid variants and alternative technologies for use in our global commercial vehicle markets. For the years ended December 31, 2014, 2013 and 2012, we have incurred \$103.8 million, \$97.1 million and \$115.1 million of engineering – research and development expense, respectively.

From time to time, we acquire certain licenses to provide us with technology to complement our portfolio of products and product initiatives, such as our engineering development agreement with Torotrak plc and our development agreement with Fallbrook Technologies, Inc. For the years ended December 31, 2014, 2013 and 2012, we have incurred \$6.1 million, \$6.0 million and \$12.0 million, respectively, of engineering – research and development expense related to technology-related licenses.

We maintain test tracks on our Indianapolis, Indiana campus and at our location in Szentgotthard, Hungary for vehicle drive, testing and calibration activities in addition to being a demonstration venue for customers. We also use test track facilities in New Carlisle, Indiana and Apache Junction, Arizona.

Sales and Marketing Organization

Our sales and marketing effort is organized along geographic and customer lines and is comprised of marketing, sales and service professionals, supported by application engineers worldwide. In North America, selling efforts in the on-highway end market are organized by distributor area responsibility, OEM sales and national accounts, for our large end users. Outside North America, we manage our sales, marketing, service and application engineering professionals through regional areas of responsibility. These regional management teams distribute OEM service and application engineering resources globally. We manage our defense products sales, marketing, service and application engineering through professionals based in Indianapolis, Indiana and Detroit, Michigan.

We have developed a marketing strategy to reach OEM customers as well as end users. We target our end users primarily through marketing activities by our sales staff, who directly call end users and attend local trade shows, targeting specific vocations globally and through our plant tour programs, where end users may test our products on the Indianapolis test track and our enhanced customer experience demonstration track at our Hungary facility.

While our marketing management uses the term “customer” interchangeably for OEMs and end users, the primary objective of our marketing strategy is to create demand for fully-automatic transmissions through:

- OEM promotion of our products and incorporation of fully-automatic transmissions in their commercial vehicle product offerings;
- Allison representative and/or Allison distributor contact with identified, major end users; and
- our network of independent dealers who contact other end users.

The process is interactive, as Allison representatives, Allison distributors and OEM dealers educate customers and respond to the specific applications, requirements and needs of numerous specialty markets.

Similarly, we work with customers, dealers and OEMs to educate, improve and simplify how they specify vehicles and vehicle systems in order to optimize vehicle performance and fuel consumption. Our field organization also works closely with distributors who, in turn, work with dealers to provide end users with education, parts, service and warranty support. The defense marketing group follows a defined plan that identifies country, vehicle and specific OEMs and then approaches the ultimate end user through a variety of channels.

Manufacturing

Our manufacturing strategy provides for distributed capability in manufacturing and assembly of our products for the global commercial vehicle market. Our primary manufacturing facilities, located in Indianapolis, Indiana, consist of approximately 2.3 million square feet of usable manufacturing space in six plants. We also have established customization and parts distribution in the United States, The Netherlands, Brazil, China, Hungary, India and Japan, and plants in Chennai, India and Szentgotthard, Hungary. Our high volume on-highway products are produced in multiple global locations while off-highway, hybrid-propulsion and defense tracked products are produced in Indianapolis.

Suppliers and Raw Materials

A significant amount of the part numbers that make up our transmissions are purchased from outside suppliers, and during 2014, we purchased approximately \$750.0 million of direct materials and components from outside suppliers. The largest elements of our direct spending are aluminum and steel castings and forgings that are formed by our suppliers into our larger components and assemblies for use in our transmissions. However, our spending on aluminum and steel raw materials directly and indirectly through our purchase of these components constituted approximately 10% of our direct material and component costs in 2014. The balance of our direct and indirect materials and components costs are primarily composed of value-added services and conversion costs. Our supply contracts, along with an intensive supplier selection and performance monitoring process, have enabled us to establish and maintain close relationships with suppliers and have contributed to our overall operating efficiency and industry-leading quality.

Intellectual Property

Patents and other proprietary rights are important to the continued success of our business. We also rely upon trade secrets, know-how, continuing technological innovation and licensing opportunities to develop and maintain our competitive position. We protect our proprietary rights through a variety of methods, including confidentiality agreements and proprietary information agreements with suppliers, employees, consultants and others who may have access to proprietary information. We own 79 issued patents, and we have licensing arrangements with respect to more than 600 additional issued patents. We have more than 200 pending patent applications throughout the world that relate to aspects of the technology incorporated in many of our products.

In addition, in conjunction with the sale of Allison (the "Acquisition Transaction") by Old GM, we acquired an irrevocable, royalty-free, worldwide license of more than 400 U.S. and foreign patents and patent applications, as well as certain unpatented technology and know-how, to manufacture, use and sell fully-automatic transmissions and certain hybrid-propulsion systems for use in vocational and defense vehicles and off-highway products. Such licenses are subject to certain limitations. See Part I, Item 1A, "Risk Factors" of this Annual Report on Form 10-K for a complete discussion of these risks and limitations. In addition, we acquired from Old GM an irrevocable, royalty-free, worldwide license under computer software programs that we use to run our business, including product design. Allison also acquired ownership of trademarks and copyrights relating to our business, subject in some cases to a non-exclusive license back to Old GM for use in connection with its existing six-speed A1000 transmission products, but only up to the termination of production of the A1000 transmission product by General Motors Company ("GM"), the successor to Old GM. GM has assumed Old GM's obligations under these agreements pursuant to an agreement between us and GM in which GM assumed certain contracts and agreements between us and Old GM (the "Cure Agreement").

Seasonality

Overall, the demand for our products is relatively consistent over the year. However, in typical market conditions, the North American truck market experiences a higher level of production in the first half of the year due to fewer holidays and the practice of plant shutdowns in July and December. Working capital levels do not fluctuate significantly in the normal course for our business.

Employees

As of December 31, 2014, we had approximately 2,700 employees, with more than 90% of those employees in the U.S. Approximately 60% of our U.S. employees are represented by the International Union, United Automobile, Aerospace and Agricultural Implement Workers of America ("UAW") and are subject to a collective bargaining agreement. In November 2012, we entered into a five year agreement with the UAW Local 933 that expires in November 2017. As approximately 50% of our represented employees are currently retirement eligible, we anticipate a shift toward increasing the number of second tier employees over the coming years. There have been no strikes or work stoppages due to Allison-specific issues in over 30 years.

Environmental Compliance

We are subject to a variety of federal, state, local and foreign environmental laws and regulations, including those governing the discharge of pollutants into the air or water, the management and disposal of hazardous substances or wastes, and the cleanup of contaminated sites. Some of our operations require environmental permits and controls to prevent and reduce air and water pollution. These permits are subject to modification, renewal and revocation by issuing authorities. In addition, certain of our products and our customer's products are subject to certification requirements by a variety of regulatory bodies. We believe we are in substantial compliance with all material environmental laws and regulations applicable to our plants and operations. Historically, our costs of achieving and maintaining compliance with environmental, health and safety requirements have not been material to our results.

Increasing global efforts to control emissions of carbon dioxide, methane, ozone, nitrogen oxide ("NOx") and other greenhouse gases and pollutants, as well as the shifting focus of regulatory efforts towards total emissions output, have the potential to impact our facilities, costs, products and customers. The U.S. Environmental Protection Agency ("EPA") has taken action to control greenhouse gases from certain stationary and mobile sources. In addition, the U.S. Congress is considering proposals to limit greenhouse gas emissions, and several states have taken steps, such as adoption of cap and trade programs or other regulatory systems, to address greenhouse gases. There have also been international efforts seeking legally binding reductions in emissions of greenhouse gases. These developments and further actions that may be taken in the U.S. and in other countries, states or provinces could affect our operations both positively and negatively (e.g., by affecting the demand for or suitability of some of our products).

We also may be subject to liability as a potentially responsible party under the Comprehensive Environmental Response, Compensation and Liability Act and similar state or foreign laws for contaminated properties that we currently own, lease or operate or that we or our predecessors have previously owned, leased or operated, and sites to which we or our predecessors sent hazardous substances. Such liability may be joint and several so that we may be liable for more than our share of contamination, and any such liability may be determined without regard to causation or knowledge of contamination. We or our predecessors have been named potentially responsible parties at contaminated sites from time to time. We do not anticipate our liabilities relating to contaminated sites will be material to our results.

Also, under the Asset Purchase Agreement, Old GM agreed to indemnify us against certain environmental liabilities, including pre-Acquisition Transaction offsite waste disposal from our facilities, former facilities associated with our business and any properties or facilities relating to our business that Old GM retained. While we are presently responsible for environmental liabilities that arise due to our post-Acquisition Transaction activities, GM, as successor to Old GM's obligations pursuant to the Cure Agreement, continues to perform remedial activities at our Indianapolis, Indiana manufacturing facilities relating to historical soil and groundwater contamination at the facilities. GM is performing such activities, which we refer to as the "Corrective Action", pursuant to the Asset Purchase Agreement, whereby it retained responsibility for completing all obligations covered by a voluntary Corrective Action Agreement that Old GM entered with the EPA. Once the EPA determines that GM's remedial activities are complete and that the migration of any contamination is under control, we will assume responsibility for operating, monitoring and maintaining the ongoing Corrective Action activities and it is likely this will be performed under an agreed order of consent ("AOC") with the EPA. It is likely that the AOC will require us to provide financial assurances to complete the operation, monitoring and maintenance activities in the event we fail to do so. This financial assurance can take a variety of forms including, but not limited to meeting certain financial metrics, providing a letter of credit, or securing a bond or an insurance policy. We have not yet established accruals for our expected future liability with respect to this activity, as we do not yet know the estimated cost. Once the EPA determines that GM's remedial activities are complete as described above, and we assume responsibility for operating, monitoring and maintaining the ongoing Corrective Action activities previously managed by GM, we will be responsible for all environmental liabilities that may arise at any of our properties, including with respect to contamination that may have occurred at our properties prior to the Acquisition Transaction. Additionally, there can be no assurances that GM will comply with its indemnity obligations or with its remedial obligations at the Indianapolis, Indiana manufacturing facilities, or that future environmental remediation obligations will not have a material adverse impact on our results.

Competition

We compete on the basis of product performance, quality, price, distribution capability and service in addition to other factors. We face competition from numerous manufacturers of various types of transmissions for commercial vehicles, such as manual transmissions, AMTs and fully-automatic transmissions. We also face competition from manufacturers in our international operations and from international manufacturers entering our domestic market. Furthermore, some of our customers are OEMs that manufacture transmissions for their own products. Despite their transmission manufacturing abilities, our existing OEM customers have chosen to purchase certain transmissions from us due to the quality, reliability and strong brand of our transmissions and in order to limit fixed costs, minimize production risks and maintain company focus on commercial vehicle design, production and marketing.

Corporate Information

Allison Transmission Holdings, Inc. was incorporated in Delaware on June 22, 2007. Our principal executive offices are located at One Allison Way, Indianapolis, IN 46222 and our telephone number is (317) 242-5000. Our internet address is www.allisontransmission.com. We file annual, quarterly and current reports, proxy statements and other documents with the United States Securities and Exchange Commission (“SEC”), under the Securities Exchange Act of 1934, as amended (the “Exchange Act”). These periodic and current reports and all amendments to those reports are available free of charge on the investor relations page of our website at <http://ir.allisontransmission.com>. We have included our website address throughout this filing as textual references only. The information contained on our website is not incorporated into this Annual Report on Form 10-K. The public may read and copy any materials we file with the SEC at the SEC’s Public Reference Room at 100 F Street, NE, Washington, DC 20549. The public may obtain information on the operation of the Public Reference Room by calling the SEC at 1-800-SEC-0330. The SEC also maintains an Internet site that contains reports, proxy and information statements, and other information regarding issuers that file electronically with the SEC at <http://www.sec.gov>.

ITEM 1A. Risk Factors

The following is a cautionary discussion of risks, uncertainties and assumptions that we believe are significant to our business. In addition to the factors discussed elsewhere in this Annual Report on Form 10-K, the following are some of the important factors that, individually or in the aggregate, we believe could make our actual results differ materially from those described in any forward-looking statements. It is impossible to predict or identify all such factors and, as a result, you should not consider the following factors to be a complete discussion of risks, uncertainties and assumptions.

Risks Related to Our Business

We participate in markets that are competitive, and our competitors' actions could have a material adverse effect on our business, results of operations and financial condition.

Our business operates in competitive markets. We compete against other global manufacturers on the basis of product performance, quality, price, distribution capability and service in addition to other factors. Actions by our competitors could lead to downward pressure on prices and/or a decline in our market share, either or both of which could adversely affect our results. We face competition from domestic manufacturers of manual transmissions, AMTs and fully-automatic transmissions for commercial vehicles. In particular, we could face competition from well-capitalized entrants into the transmission market, as well as from aggressive pricing tactics by other transmission manufacturers trying to gain market share. We also face competition from international manufacturers in our international markets and from international manufacturers entering our domestic market.

In addition, some of our customers or future customers are OEMs that manufacture or could in the future manufacture transmissions for their own products. Despite their transmission manufacturing abilities, our existing OEM customers have chosen to purchase certain transmissions from us due to customer demand, resulting from the quality of our transmission products and in order to reduce fixed costs, eliminate production risks and maintain company focus. However, we cannot be certain these customers will continue to purchase our products in the future. Increased levels of production insourcing by these customers could result from a number of factors, such as shifts in our customers' business strategies, acquisition by a customer of another transmission manufacturer, the inability of third-party suppliers to meet specifications and the emergence of low-cost production opportunities in foreign countries. As a result, these OEMs may use transmissions produced internally or by another manufacturer and no longer choose to purchase transmissions from us. A significant reduction in the level of external sourcing of transmission production by our OEM customers could significantly impact our net sales and cash flows and, accordingly, have a material adverse effect on our business, results of operations and financial condition.

Certain of our end users operate in highly cyclical industries, which can result in uncertainty and significantly impact the demand for our products, which could have a material adverse effect on our business, results of operations and financial condition.

Some of the markets in which we operate, including energy, mining, construction, distribution and motorhomes, exhibit a high degree of cyclicity. Decisions to purchase our transmissions are largely a result of the performance of these and other industries we serve. If demand for output in these industries decreases, the demand for our products will likely decrease. Demand in these industries is impacted by numerous factors including prices of commodities, rates of infrastructure spending, housing starts, real estate equity values, interest rates, consumer spending, fuel costs, energy demands, municipal spending and commercial construction, among others. Increases or decreases in these variables globally may significantly impact the demand for our products, which could have a material adverse effect on our business, results of operations and financial condition. If we are unable to accurately predict demand, we may be unable to meet our customers' needs, resulting in the loss of potential sales, or we may manufacture excess products, resulting in increased inventories and overcapacity in our production facilities, increasing our unit production cost and decreasing our operating margins.

Our long-term growth prospects and results of operations may be impaired if the rate of adoption of fully-automatic transmissions in commercial vehicles outside North America does not increase.

Our long-term growth strategy depends in part on an increased rate of automaticity outside North America. As part of that strategy, we have established manufacturing facilities in India and Hungary. We have also dedicated significant human resources to serve markets where we anticipate increased adoption of automaticity, including China, India, Brazil and Russia. However, manual transmissions remain the market leader outside North America and there can be no assurance that adoption of automatic transmissions will increase. Factors potentially impacting adoption of automatic transmissions outside of North America may include the large existing installed base of manual transmissions, customer preferences for manual transmissions, commercial vehicle OEM integration into manual transmission and AMT manufacturing, and failure to further develop the Allison brand. If the rate of adoption of fully-automatic transmissions does not increase as we have anticipated, our long-term growth prospects and results of operations may be impaired.

Our sales are concentrated among our top five OEM customers and the loss or consolidation of any one of these customers or the discontinuation of particular vehicle models for which we are a significant supplier could reduce our net sales and have a materially adverse effect on our results of operations.

We have in the past and may in the future derive a significant portion of our net sales from a relatively limited number of OEM customers. For the years ended December 31, 2014, 2013 and 2012, our top five customers accounted for approximately 45%, 48% and 45% of our net sales, respectively. Our top two customers, Daimler and Navistar, accounted for approximately 17% and 10%, respectively, of our net sales during 2014. The commercial vehicle industry, including our customers and suppliers, continues to experience volatility and uncertainty. The loss of, or consolidation of any one of these customers, or a significant decrease in business from, one or more of these customers could harm our business. In addition, the discontinuation of particular vehicle models for which we are a significant supplier could reduce our net sales and have a material adverse effect on our results of operations.

Sales of our hybrid-propulsion systems have been, and may continue to be, negatively impacted by governmental entities electing not to subsidize the purchase of such products by end users and other external factors.

The sales of our hybrid-propulsion systems for use in transit buses have been, and may continue to be, negatively impacted by governmental entities electing not to subsidize the purchase of such products by end users. In 2014, we derived approximately 4% of our net sales from the sale of hybrid-propulsion systems for use in transit buses to city, state and federal governmental end users. Such end users may be eligible to receive certain subsidies as a result of their purchase of vehicles using hybrid-propulsion systems. For example, the Federal Transit Authority and the DOE provide funds for end users to pursue alternative fuel propulsion systems. While we do not directly receive these subsidies, if any of the subsidizing entities elect to curtail such subsidies to end users for any reason including governmental budget reductions and related fiscal matters, failure of our hybrid technology to qualify for such subsidies or redundancy by alternative technologies created by our competitors, our sales from our hybrid-propulsion systems may be negatively impacted. In addition, other external factors, including diesel and natural gas fuel price trends, emissions and on-board diagnostics regulatory requirements, availability of compatible engine calibrations from engine manufacturers and alternative emerging green technologies, have, and may continue to, negatively impact sales of our hybrid-propulsion systems. For the years ended December 31, 2014, 2013 and 2012, we experienced decreases in revenue generated from hybrid-propulsion systems for use in transit buses of 11%, 9% and 14%, respectively.

A majority of our sales to the defense end market are to U.S. government entities, and the loss of a significant number of our contracts, budgetary declines or future reductions or changes in U.S. government spending would have a material adverse effect on our results of operations and financial condition.

Our net sales to the defense end market are predominantly derived from contracts (revenue arrangements) with agencies of, and prime system contractors to, the U.S. government. If a significant number of our DOD contracts and subcontracts are simultaneously delayed or cancelled for budgetary, performance or other reasons, it would have a material adverse effect on our results of operations and financial condition. Approximately 7%, or \$157 million, of our net sales for the year ended December 31, 2014 were made directly or indirectly to U.S. government agencies, including the DOD.

Sales in our defense end market have been, and we expect will continue to be, negatively impacted by declining DOD spending on wheeled and tracked vehicles. In addition to declines in defense budgets, our future financial results may be adversely affected by:

- curtailment of the U.S. government's use of technology or other services and product providers, including curtailment due to government budget reductions, future government shutdowns and related fiscal matters;
- geopolitical developments that affect demand for our products and services; and
- technological developments that impact purchasing decisions or our competitive position.

Continued volatility in and disruption to the global economic environment could adversely affect the ability of customers and suppliers to obtain credit and may have a material adverse effect on our business, results of operations and financial condition.

The commercial vehicle industry as a whole has been more adversely affected by volatile economic conditions than many other industries, as the purchase or replacement of commercial vehicles, which are durable items, can be deferred for many reasons, including reduced spending by end users. Furthermore, financial instability or bankruptcy at any of our suppliers or customers could disrupt our ability to manufacture our products and impair our ability to collect receivables, any or all of which may have a material adverse effect on our business, results of operations and financial condition. In addition, some of our customers and suppliers may experience serious cash flow problems and, thus, may find it difficult to obtain financing, if financing is available at all. As a result, our customers' need for and ability to purchase our products or services may decrease, and our suppliers may increase their prices, reduce their output or change their terms of sale. Any inability of customers to pay us for our products and services, or any demands by suppliers for different payment terms, may materially and adversely affect our results of operations and financial condition. Furthermore, our suppliers may not be successful in generating sufficient sales or securing alternate financing arrangements, and therefore may no longer be able to supply goods and services to us. In that event, we would need to find alternate sources for these goods and services, and there is no assurance we would be able to find such alternate sources on favorable terms, if at all. Any such disruption in our supply chain could adversely affect our ability to manufacture and deliver our products on a timely basis, and thereby affect our results of operations.

Any events that impact our brand name, including if the products we manufacture or distribute are found to be defective, could have an adverse effect on our reputation, cause us to incur significant costs and negatively impact our business, results of operations and financial condition.

We face exposure to product liability claims in the event that the use of our products has, or is alleged to have, resulted in injury, death or other adverse effects. We currently maintain product liability insurance coverage, but we cannot be assured that we will be able to obtain such insurance on acceptable terms in the future, if at all, or that any such insurance will provide adequate coverage against potential claims. Product liability claims can be expensive to defend and can divert the attention of management and other personnel for long periods of time, regardless of the ultimate outcome. An unsuccessful product liability defense could have a material adverse effect on our business, results of operation, financial condition or prospects. If one of our products is determined to be defective, we may face substantial warranty costs and may be responsible for significant costs associated with a product recall or a redesign. We have had defect and warranty issues associated with certain of our products in the past, such as our H 40/50 EP hybrid-propulsion transit bus system, where certain units were falling short of their expected service life and we offered repair and replacement for an extended period. See NOTE 9 of Notes to Consolidated Financial Statements included in Part II, Item 8 of this Annual Report on Form 10-K for additional details regarding this warranty issue. We cannot give assurance similar product defects will not occur in the future.

Furthermore, our business depends on the strong brand reputation we have developed. In addition to the risk of defective products we face with our new product installations, we also face significant risks in our efforts to penetrate new markets, where we have limited brand recognition. We also rely on our reputation with end users of our transmissions to specify our transmissions when purchasing new vehicles from our OEM customers. In the event we are not able to maintain or enhance our brand in these new markets or our reputation is damaged in our existing markets as a result of product defects or recalls, we may face difficulty in maintaining our pricing positions with respect to some of our products or experience reduced demand for our products, which could negatively impact our business, results of operations and financial condition.

Our brand and reputation are dependent on the continued participation and level of service of our numerous independent distributors and dealers.

We work with a network of approximately 1,400 independent distributors and dealers that provide post-sale service and parts and support equipment. Because we depend on the pull-through demand generated by end users for our products, any actions by the independent distributors or dealers, which are not in our control, may harm our reputation and damage the brand loyalty among our customer base. In the event that we are not able to maintain our brand reputation because of the actions of our independent distributors and dealers, we may face difficulty in maintaining our pricing positions with respect to some of our products or have reduced demand for our products, which could negatively impact our business, results of operations and financial condition. In addition, if a significant number of independent dealers were to terminate their contracts, it could adversely impact our business, results of operations and financial condition.

We may not be successful in introducing our new products and responding to customer needs.

We recently began production of the TC10 and currently have additional new products and technologies under development. The development of new products and technologies is difficult and the timetable for commercial release is uncertain, and we may not be successful in introducing our new products and responding to customer needs. In addition, it often takes significant time, in some cases multiple fleet buy cycles, before customers gain experience with new products and technologies and those new products and technologies become widely-accepted by the market. If we do not adequately anticipate the changing needs of our customers by developing and introducing new and effective products and technologies on a timely basis, our competitive position and prospects could be harmed. If our competitors are able to respond to changing market demands and adopt new technologies more quickly than we do, demand for our products could decline, our competitive position could be harmed, and we will not be able to recoup a return on our development investments. Moreover, changing customer demands as well as evolving safety and environmental standards could require us to adapt our products and technologies to address such changes. As a result, in the future we may experience delays in the introduction of some or all of our new products or modifications or enhancements of existing products. Furthermore, there may be production delays due to unanticipated technological setbacks, which may, in turn, delay the release of new products to our end users. If we experience significant delays in production, our net sales and results of operations may be materially adversely affected.

Our success depends on continued research and development efforts, the outcome of which is uncertain.

Our success depends on our ability to improve the efficiency and performance of our transmissions, and we invest significant resources in research and development in order to do so. Nevertheless, the research and development process is time-consuming and costly, and offers uncertain results. We may not be able through our research and development efforts to keep pace with improvements in transmission-related technology of our competitors, and licenses for technologies that would enable us to keep pace with our competitors may not be available on commercially reasonable terms if at all. Finally, our research and development efforts, and generally our ability to introduce improved products in the marketplace, may be constrained by the patents and other intellectual property rights of competitors and others.

Our international operations, in particular our emerging markets, are subject to various risks which could have a material adverse effect on our business, results of operations and financial condition.

Our business is subject to certain risks associated with doing business internationally, particularly in emerging markets. Outside-North America net sales represented approximately 20% of our net sales for 2014. Most of our operations are in the U.S., but we also have manufacturing and customization facilities in India and Hungary with a services agreement with Opel Szentgotthard Automotive Manufacturing Ltd., formerly GM-PTH, and customization capability in Brazil, The Netherlands, China and Japan. Further, we intend to continue to pursue growth opportunities for our business in a variety of business environments outside the U.S., which could exacerbate the risks set forth below. Our international operations are subject to, without limitation, the following risks:

- the burden of complying with multiple and possibly conflicting laws and any unexpected changes in regulatory requirements;
- foreign currency exchange controls, import and export restrictions and tariffs, including restrictions promulgated by the Office of Foreign Assets Control of the U.S. Department of the Treasury, and other trade protection regulations and measures;
- political risks, including risks of loss due to civil disturbances, acts of terrorism, acts of war, guerilla activities and insurrection;
- unstable economic, financial and market conditions and increased expenses as a result of inflation, or higher interest rates;
- difficulties in enforcement of third-party contractual obligations and intellectual property rights and collecting receivables through foreign legal systems;
- difficulty in staffing and managing international operations and the application of foreign labor regulations;
- differing local product preferences and product requirements;
- fluctuations in currency exchange rates to the extent that our assets or liabilities are denominated in a currency other than the functional currency of the country where we operate;
- potentially adverse tax consequences from changes in tax laws, requirements relating to withholding taxes on remittances and other payments by subsidiaries and restrictions on our ability to repatriate dividends from our subsidiaries; and
- exposure to liabilities under anti-corruption and anti-money laundering laws, including the U.S. Foreign Corrupt Practices Act (“FCPA”) and similar laws and regulations in other jurisdictions.

Any one of these factors could materially adversely affect our sales of products or services to international customers or harm our reputation, which could have a material adverse effect on our business, results of operations and financial condition.

Our international operations require us to comply with anti-corruption laws and regulations of the U.S. government and various international jurisdictions.

Doing business on a worldwide basis requires us and our subsidiaries to comply with the laws and regulations of the U.S. government and various international jurisdictions, and our failure to comply with these rules and regulations may expose us to liabilities. These laws and regulations may apply to companies, individual directors, officers, employees and agents, and may restrict our operations, trade practices investment decisions and partnering activities. In particular, our international operations are subject to U.S. and foreign anti-corruption laws and regulations, such as the FCPA. The FCPA prohibits U.S. companies and their officers, directors, employees and agents acting on their behalf from corruptly offering, promising, authorizing or providing anything of value to foreign officials for the purposes of influencing official decisions or obtaining or retaining business or otherwise obtaining favorable treatment. The FCPA also requires companies to make and keep books, records and accounts that accurately and fairly reflect transactions and dispositions of assets and to maintain a system of adequate internal accounting controls. As part of our business, we deal with state-owned business enterprises, the employees and representatives of which may be considered foreign officials for purposes of the FCPA. In addition, some of the international locations in which we operate lack a developed legal system and have elevated levels of corruption. As a result of the above activities, we are exposed to the risk of violating anti-corruption laws. Violations of these legal requirements are punishable by criminal fines and imprisonment, civil penalties, disgorgement of profits, injunctions, debarment from government contracts as well as other remedial measures. We have established policies and procedures designed to assist us and our personnel in complying with applicable U.S. and international laws and regulations. However, our employees, subcontractors and agents could take actions that violate these requirements, which could adversely affect our reputation, business, financial condition and results of operations.

Labor unrest could have a material adverse effect on our business, results of operations and financial condition.

As of December 31, 2014, approximately 60% of our U.S. employees, representing over 50% of our total employees, were represented by the UAW and are subject to a collective bargaining agreement. In November 2012, we reached an agreement on a new five-year collective bargaining agreement with the UAW Local 933, which is effective through November 2017.

In addition to our unionized work force, many of our direct and indirect customers and vendors have unionized work forces. Strikes, work stoppages or slowdowns experienced by these customers or vendors or their other suppliers could result in slowdowns or closings of assembly plants that use our products or supply materials for use in the production of our products. Organizations responsible for shipping our products may also be impacted by strikes. Any interruption in the delivery of our products could reduce demand for our products and could have a material adverse effect on us.

In general, we consider our labor relations with all of our employees to be good. However, in the future we may be subject to labor unrest. The inability to reach a new agreement could delay or disrupt our operations in the affected regions, including the acquisition of raw materials and components, the manufacture, sales and distribution of products and the provision of services. If strikes, work stoppages or lock-outs at our facilities or at the facilities of our vendors or customers occur or continue for a long period of time, our business, results of operations and financial condition may be materially adversely affected.

In the event of a catastrophic loss of our key manufacturing facility, our business would be adversely affected.

While we manufacture our products in several facilities and maintain insurance covering our facilities, including business interruption insurance, a catastrophic loss of the use of all or a portion of one of our manufacturing facilities due to accident, labor issues, weather conditions, acts of war, political unrest, terrorist activity, natural disaster or otherwise, whether short- or long-term, would have a material adverse effect on our business, results of operations and financial condition. Our most significant concentration of manufacturing is around our corporate headquarters in Indianapolis, Indiana where we produce approximately 90% of our transmissions. In addition to our Indianapolis manufacturing facilities, we currently operate manufacturing facilities in both Szentgotthard, Hungary and Chennai, India. In the event of a disruption at the Indianapolis facilities, they may not be adequately equipped to operate at a level sufficient to compensate for the volume of production at the Indianapolis facility due to their size and the fact that they have not yet been tested for such significant increases in production volume.

Increases in cost, disruption of supply or shortage of raw materials or components used in our products could harm our business and profitability.

Our products contain various raw materials, including corrosion-resistant steel, non-ferrous metals such as aluminum and nickel, and precious metals such as platinum and palladium. We use raw materials directly in manufacturing and in transmission components that we purchase from our suppliers. We generally purchase components with significant raw material content on the open market. The prices for these raw materials fluctuate depending on market conditions. Volatility in the prices of raw materials such as steel, aluminum and nickel could increase the cost of manufacturing our products. We may not be able to pass on these costs to our customers, and this could have a material adverse effect on our business, results of operations and financial condition. Even in the event that increased costs can be passed through to customers, our gross margin percentages would decline. Additionally, our suppliers are also subject to fluctuations in the prices of raw materials and may attempt to pass all or a portion of such increases on to us. In the event they are successful in doing so, our margins would decline.

In 2014, approximately 75% of our total spending on components was sourced from approximately 40 suppliers. All of the suppliers from which we purchase materials and components used in our business are fully validated suppliers, meaning the suppliers' manufacturing processes and inputs have been validated under a production part approval process ("PPAP"). Furthermore, there are only a limited number of suppliers for certain of the materials used in our business, such as corrosion-resistant steel. As a result, our business is subject to the risk of additional price fluctuations and periodic delays in the delivery of our materials or components if supplies from a validated supplier are interrupted and a new supplier must be validated or materials and components must be purchased from a supplier without a completed PPAP. Any such price fluctuations or delays, if significant, could harm our profitability or operations. In addition, the loss of a supplier could result in significant material cost increases or reduce our production capacity. We also cannot guarantee we will be able to maintain favorable arrangements and relationships with these suppliers. An increase in the cost or a sustained interruption in the supply or shortage of some of these raw materials or components that may be caused by a deterioration of our relationships with suppliers or by events such as natural disasters, power outages, labor strikes, or the like could negatively impact our business, results of operations and financial condition. Although we have agreements with many of our customers that we will pass such price increases through to them, such contracts may be cancelled by our customers and/or we may not be able to recoup the costs of such price increases. Additionally, if we are unable to continue to purchase our required quantities of raw materials on commercially reasonable terms, or at all, if we are unable to maintain or enter into purchasing contracts for commodities, or if delivery of materials from suppliers is delayed or non-conforming, our operations could be disrupted or our profitability could be adversely impacted.

Our business and financial results may be adversely affected by government contracting risks.

We are subject to various laws and regulations applicable to parties doing business with the U.S. government, including laws and regulations governing performance of U.S. government contracts, the use and treatment of U.S. government furnished property and the nature of materials used in our products. We may be unilaterally suspended or barred from conducting business with the U.S. government, or become subject to fines or other sanctions if we are found to have violated such laws or regulations. As a result of the need to comply with these laws and regulations, we are subject to increased risks of governmental investigations, civil fraud actions, criminal prosecutions, whistleblower law suits and other enforcement actions. The laws and regulations to which we are subject include, but are not limited to, Export Administration Regulations, Federal Acquisition Regulation, International Traffic in Arms Regulations, Foreign Assets Control documentation and regulations from the Bureau of Alcohol, Tobacco and Firearms and the FCPA.

U.S. government contracts are subject to modification, curtailment or termination by the U.S. government without prior written notice, either for convenience or for default as a result of our failure to perform under the applicable contract. If terminated by the U.S. government as a result of our default, we could be liable for additional costs the U.S. government incurs in acquiring undelivered goods or services from another source and any other damages it suffers. Additionally, we cannot assign prime U.S. government contracts without the prior consent of the U.S. government contracting officer, and we are required to register with the Central Contractor Registration Database. Furthermore, the U.S. government periodically audits our governmental contract costs, which could result in fines, penalties or adjustment of costs and prices under the contracts.

Many of the key patents and unpatented technology we use in our business are licensed to us, not owned by us, and our ability to use and enforce such patents and technology is restricted by the terms of the license.

Protecting our intellectual property rights is critical to our ability to compete and succeed as a company. In connection with the Acquisition Transaction, under the patent and technology license agreement (the "Patent and Technology License Agreement"), which was assumed by GM pursuant to the Cure Agreement, we were granted an irrevocable, perpetual, royalty-free, worldwide license under a large number of U.S. and foreign patents and patent applications, as well as certain unpatented technology and know-how, to design, develop, manufacture, use and sell fully-automatic transmissions and H 40/50 EP hybrid-propulsion transit bus systems for use in certain vocational vehicles, defense vehicles and off-road products. With respect to the bulk of the intellectual property licensed to us under such license agreement, our license is exclusive with respect to the design, development, manufacture, use and sale of fully-automatic transmissions and H 40/50 EP hybrid-propulsion transit bus systems in vocational vehicles above certain weight rating thresholds, certain defense vehicles and certain off-road products. It is non-exclusive with respect to certain other products that are within the scope of the licensed patents or to which the licensed technology can be applied. We consider the patents and technology licensed under such license agreement, as a whole, to be critical to preserving our competitive position in the market. However, GM continues to own such patents and technology, and pursuant to the terms of such license agreement, GM has the right, in the first instance, to control the maintenance, enforcement and defense of such patents and the prosecution of the licensed patent applications. In addition, the license agreement limits our ability to sublicense our rights. The Patent and Technology License Agreement permits us to utilize the bulk of the intellectual property rights on an exclusive basis in non-defense vehicles with gross vehicle weights above 5900 kilograms (typically Class 4 and higher) with some limited exceptions for GM light-duty pickup truck and van platforms. It also permits us to utilize the bulk of the intellectual property rights on an exclusive basis in defense vehicles that exceed 4250 kilograms (generally Class 3 to Class 4 and higher). GM continues to have the right under such patents and technology to utilize the licensed intellectual property for use in vehicles below the above mentioned rating thresholds, as well as in some light-duty van and pickup truck platforms.

We rely on unpatented technology, which exposes us to certain risks.

We currently do, and may continue in the future to, rely on unpatented proprietary technology. In such regard, we cannot be assured that any of our applications for protection of our intellectual property rights will be approved or that others will not infringe or challenge our intellectual property rights. It is possible our competitors will independently develop the same or similar technology or otherwise obtain access to our unpatented technology.

Although we believe the loss or expiration of any single patent would not have a material effect on our business, results of operations or financial position, there can be no assurance that any one, or more, of the patents licensed from GM, or any other intellectual property owned by or licensed to us, will not be challenged, invalidated or circumvented by third parties. In fact, a number of the patents licensed to us by GM have expired since the date of the Acquisition Transaction, and others are set to expire in the next few years. When a patent expires, the inventions it discloses can be used freely by others. Thus, the competitive advantage that we gain from the patents licensed to us from GM pursuant to the Acquisition Transaction will decrease over time, and a greater burden will be placed on our own research and development and licensing efforts to develop and otherwise acquire technologies to keep pace with improvements of transmission-related technology in the marketplace. We enter into confidentiality and invention assignment agreements with employees, and into non-disclosure agreements with suppliers and appropriate customers so as to limit access to and disclosure of our proprietary information. We cannot be assured that these measures will provide meaningful protection for our trade secrets, know-how or other proprietary information in the event of any unauthorized use, misappropriation or disclosure. If we are unable to maintain the proprietary nature of our technologies, our ability to sustain margins on some or all of our products may be affected, which could reduce our sales and profitability. Moreover, the protection provided for our intellectual property by the laws and courts of foreign nations may not be as advantageous to us as the protection available under U.S. law.

Our pension funding obligations could increase significantly due to a reduction in funded status as a result of a variety of factors.

Our earnings may be positively or negatively impacted by the amount of income or expense recorded for our defined benefit pension plans and other post-retirement benefits (“OPEB”). Accounting principles generally accepted in the United States of America (“GAAP”) requires that income or expense for defined benefit pension plans be calculated at the annual measurement date using actuarial assumptions and calculations. These calculations reflect certain assumptions, the most significant of which relate to the capital markets, interest rates and other economic conditions. Changes in key economic indicators can change these assumptions. These assumptions, along with the actual value of assets at the measurement date, will impact the calculation of pension expense for the year. Although GAAP pension expense and pension contributions are not directly related, the key economic indicators that affect GAAP pension expense also affect the amount of cash that we would contribute to our defined benefit pension plans. Because the values of these defined benefit pension plans’ assets have fluctuated and will fluctuate in response to changing market conditions, the amount of gains or losses that will be recognized in subsequent periods, the impact on the funded status of the defined benefit pension plans and the future minimum required contributions, if any, could have a material adverse effect on our business, results of operations and financial condition. The magnitude of such impact cannot be determined with certainty at this time. However, the effect of a one percentage point decrease in the assumed discount rate would result in an increase in the December 31, 2014 defined benefit pension plans obligation of approximately \$20.0 million. Likewise, a one percentage point decrease in the effective interest rate for determining defined benefit pension plans contributions would result in an increase in the minimum required contributions for 2015 of approximately \$4.0 million. Similarly, a one percentage point decrease in the assumed discount rate would result in an increase in the December 31, 2014 OPEB obligation of approximately \$23.7 million. As of December 31, 2014 the funded (unfunded) status of our defined benefit pension plans and OPEB plan was \$1.8 million and (\$136.0) million, respectively.

Environmental, health and safety laws and regulations may impose significant compliance costs and liabilities on us.

We are subject to many environmental, health and safety laws and regulations governing emissions to air, discharges to water, the generation, handling and disposal of waste and the cleanup of contaminated properties. Compliance with these laws and regulations is costly. We have incurred and expect to continue to incur significant costs to maintain or achieve compliance with applicable environmental, health and safety laws and regulations. Moreover, if these environmental, health and safety laws and regulations become more stringent or expand to include a larger portion of our products or our customer’s products in the future, we could incur additional costs in order to ensure that our business and products comply with such regulations. In addition, we may not be successful in complying with or the vehicle or customer OEMs to which we sell our products may choose not to comply with such laws and regulations, which could impact our ability to sell our products in certain locations. Furthermore, if our products that are already placed in service are found to be non-compliant with certain laws, regulations and certifications, we may incur additional costs and fines. We cannot assure we are in full compliance with all environmental, health and safety laws and regulations. Our failure to comply with applicable environmental, health and safety laws and regulations and permit requirements could result in civil or criminal fines, penalties or enforcement actions, third-party claims for property damage and personal injury, requirements to clean up property or to pay for the costs of cleanup or regulatory or judicial orders enjoining or curtailing operations or requiring corrective measures, including the installation of pollution control equipment or remedial actions. Our failure to comply could also result in our failure to secure adequate insurance for our business, resulting in significant exposure, diminished ability to hedge our risks and material modifications of our business operations.

We may be subject to liability as a potentially responsible party under the Comprehensive Environmental Response, Compensation and Liability Act and similar state or foreign laws for contaminated properties that we currently own, lease or operate or that we or our predecessors have previously owned, leased or operated, and sites to which we or our predecessors sent hazardous substances. Such liability may be joint and several so that we may be liable for more than our share of contamination, and any such liability may be determined without regard to causation or knowledge of contamination. We or our predecessors have been named potentially responsible parties at contaminated sites from time to time.

GM continues to perform the Corrective Action post-Acquisition Transaction pursuant to the Asset Purchase Agreement, whereby it retained responsibility for completing all obligations covered by a voluntary Corrective Action Agreement that Old GM entered with the EPA. GM retained responsibility for completing the Corrective Action and agreed to indemnify us against certain environmental liabilities as successor to Old GM’s obligations pursuant to the Cure Agreement. Once GM has received notification from EPA that the Corrective Action obligations are complete, subject to controls, we will assume responsibility for maintaining the ongoing operating, monitoring and maintenance activities required by the EPA. It is likely this will be performed under an AOC with the EPA. The costs for these activities may be material. See Part I, Item 1, “Business — Environmental Compliance” of this Annual Report on Form 10-K. There can be no assurances that GM will comply with its indemnity obligations or with its remedial obligations at the Indianapolis, Indiana facilities, or that future environmental remediation obligations will not have a material adverse effect on our results of operations. In addition, we occasionally evaluate various alternatives with respect to our facilities, including possible dispositions or closings. Investigations undertaken in connection with these activities may lead to discoveries of contamination that must be remediated, and closings of facilities may trigger remediation requirements that are not applicable to operating facilities. We may also face lawsuits brought by third parties that either allege property damage or personal injury as a result of, or seek reimbursement for costs associated with, such contamination.

We could be materially adversely affected by any failure to maintain cost controls.

We rely on our cost structure and operating discipline to achieve strong operating margins. There are many factors that could affect our ability to realize expected cost savings or achieve future cost savings that we are not able to control, including the inability to meet demand through our low-cost country sourcing initiatives; the need for unexpected significant capital expenditures; unexpected changes in commodity or component pricing that we are unable to pass on to our suppliers or customers; our inability to maintain efficiencies gained from our workforce optimization initiatives; and our failure to achieve and maintain expected cost savings from our multi-tier wage and benefit structure. Additionally, we have substantial indebtedness of approximately \$2,520.5 million as of December 31, 2014. Our inability to maintain our cost controls could adversely impact our operating margins.

Exchange rate fluctuations could adversely affect our results of operations and financial position.

As a result of the expansion of our international operations, currency exchange rate fluctuations could affect our results of operations and financial position. We expect to generate an increasing portion of our net sales and expenses in such foreign currencies as the Japanese Yen, Euro, Indian Rupee, Brazilian Real, Chinese Yuan Renminbi, Canadian Dollar, British Pound, and Hungarian Forint. Although we may enter into foreign exchange agreements with financial institutions in order to reduce our exposure to fluctuations in the value of these and other foreign currencies, these transactions, if entered into, will not eliminate that risk entirely. To the extent that we are unable to match net sales received in foreign currencies with expenses paid in the same currency, exchange rate fluctuations could have a negative impact on our results of operations and financial condition. Additionally, because our consolidated financial results are reported in U.S. Dollars, if we generate net sales or earnings in other currencies, the conversion of such amounts into U.S. Dollars can result in an increase or decrease in the amount of our net sales or earnings. Furthermore, we sell certain of our products in our non-North American markets denominated in the U.S. Dollar. To the extent that certain of the local currencies in our non-North American markets are relatively weaker than the U.S. Dollar, whether as a result of foreign governments' influence or otherwise, we could become less price competitive, which could have a material adverse effect on the results of our operations.

GM's actions may materially affect our business and operating results.

Although we are an independent company as a result of the Acquisition Transaction, GM's future actions may still have a material impact on our business and results of operations. Pursuant to the Cure Agreement after GM's emergence from bankruptcy in 2009, GM has assumed certain agreements from its predecessor, including the Asset Purchase Agreement, intellectual property and software license agreements and a hybrid co-branding agreement. GM's failure to comply with any portion of these agreements for any reason, including the indemnities therein, could inhibit us from operating and expanding our business in the future.

Additionally, GM has received a non-exclusive, royalty-free, worldwide license to use the "Allison Transmission" name and certain related trademarks on GM's line of A1000 transmissions for use primarily in Class 2 and 3 pick-up trucks. If GM, or any of its subsidiaries or affiliated entities, or any third party uses the trade name "Allison Transmission" in ways that adversely affect such trade name or trademark, our reputation could suffer damage, which in turn could have a material adverse effect on our business, results of operations and financial condition.

In connection with the Acquisition Transaction, we entered into a mutual non-compete agreement with GM that restricts GM from competing with us in non-defense vehicles in North America with gross vehicle weights above 5900 kilograms (typically Class 4 and higher) with some limited exceptions for certain GM light-duty pickup truck and van platforms. It also restricts GM from competing with us in defense vehicles globally and in non-defense vehicles outside North America that exceed 4250 kilograms (generally Class 3 to Class 4 and higher) with some limited exceptions. The non-compete periods extend until August 2017 globally, except in Europe, where they expired in 2012. Similarly, we are restricted from competing with GM in weight classes below the above mentioned thresholds for similar periods of time. Upon expiration of the non-competition periods, both Allison and GM will be permitted to compete with each other but such expiration will generally not affect Allison's rights under the Patent and Technology License Agreement to use on an exclusive basis within its respective weight classes (subject to previously mentioned exceptions) the intellectual property that is licensed to Allison on an exclusive basis.

In addition, because of our current manufacturing services agreement with Opel Szentgotthard Automotive Manufacturing Ltd., a GM subsidiary, we may be materially adversely affected by the failure of GM to perform as expected. This non-performance may consist of delays or failures caused by production issues. The risk of non-performance may also result from the insolvency or bankruptcy of GM. GM's ability to provide personnel and technical resources to us is also subject to a number of risks, including destruction of our equipment or work stoppages. In addition, our failure to provide an adequate facility, or order sufficient quantities of inventory, may increase the cost of production or may lead to GM refusing to provide resources to us at all. Our efforts to protect against and to minimize these risks may not always be effective.

An impairment in the carrying value of goodwill or other indefinite-lived intangible assets could negatively affect our consolidated results of operations and net worth.

Pursuant to GAAP, we are required to assess our goodwill and indefinite-lived intangible assets to determine if they are impaired on an annual basis, or more often if events or changes in circumstances indicate that impairment may have occurred. Intangible assets with finite lives are amortized over the useful life and are reviewed for impairment on triggering events such as events or changes in circumstances indicating that an impairment may have occurred. If the testing performed indicates that impairment has occurred, we are required to record a non-cash impairment charge for the difference between the carrying value of the goodwill and the implied fair value of the goodwill or the carrying value of the intangible assets and the fair value of the intangible assets in the period the determination is made. Disruptions to our business, end market conditions, protracted economic weakness and unexpected significant declines in operating results may result in charges for goodwill and other asset impairments.

Our annual goodwill and trade name impairment test for the year ended December 31, 2014 resulted in no impairment. Although our analysis regarding the fair values of our goodwill and trade name indicates that they exceed their carrying values, materially different assumptions regarding the future performance of our business could result in impairment losses. See NOTE 2 and NOTE 5 of Notes to Consolidated Financial Statements included in Part II, Item 8 of this Annual Report on Form 10-K for additional details.

Provisions of our amended and restated certificate of incorporation and amended and restated bylaws and Delaware law might discourage, delay or prevent a change of control of our company or changes in our management and, as a result, depress the trading price of our common stock.

Our amended and restated certificate of incorporation and amended and restated bylaws contain provisions that could discourage, delay or prevent a change in control of our company or changes in our management that the stockholders of our company may deem advantageous. These provisions:

- authorize the issuance of blank check preferred stock that our Board of Directors could issue to increase the number of outstanding shares and to discourage a takeover attempt;
- limit the ability of stockholders to remove directors only “for cause”;
- prohibit our stockholders from calling a special meeting of stockholders;
- prohibit stockholder action by written consent, which requires all stockholder actions to be taken at a meeting of our stockholders;
- provide that the Board of Directors is expressly authorized to adopt, or to alter or repeal our bylaws;
- establish advance notice requirements for nominations for election to our Board of Directors or for proposing matters that can be acted upon by stockholders at stockholder meetings;
- establish a classified Board of Directors, with three staggered terms; and
- require the approval of holders of at least two-thirds of the outstanding shares of common stock to amend the bylaws and certain provisions of the certificate of incorporation.

These anti-takeover defenses could discourage, delay or prevent a transaction involving a change in control of our company. These provisions could also discourage proxy contests and make it more difficult for our stockholders to elect directors of their choosing and cause us to take corporate actions other than those they desire.

Risks Related to Our Indebtedness

Our substantial indebtedness could adversely affect our financial health, restrict our activities and affect our ability to meet our obligations.

We have a significant amount of indebtedness. As of December 31, 2014, we had total indebtedness of \$2,520.5 million and we would have been able to borrow an additional \$455.1 million under the revolving portion of our credit facility, less \$9.9 million of letters of credit. As of December 31, 2014, we had no outstanding borrowings against the revolving credit facility. Of our total indebtedness at December 31, 2014, \$2,049.2 million consists of the term loans under ATI's credit facility, including \$283.6 million of indebtedness associated with ATI's Senior Secured Credit Facility Term B-2 Loan due 2017 ("Term B-2 Loan"), \$1,765.6 million of indebtedness associated with ATI's Senior Secured Credit Facility Term B-3 Loan due 2019 ("Term B-3 Loan," and together with the Term B-2 Loan and revolving credit facility, the "Senior Secured Credit Facility"). We also had indebtedness of \$471.3 million of ATI's 7.125% senior cash pay notes due May 2019 ("7.125% Senior Notes"). For a complete description of the terms of the Senior Secured Credit Facility and the 7.125% Senior Notes, please see Part II, Item 7, "Management's Discussion and Analysis of Financial Condition and Results of Operations – Recent Developments," "– Description of the Senior Secured Credit Facility" and "– Description of the Senior Notes."

Our substantial indebtedness could have important consequences. For example, it could:

- make it more difficult for us to satisfy our obligations under our indebtedness;
- require us to further dedicate a substantial portion of our cash flow from operations to payments of principal and interest on our indebtedness, thereby reducing the availability of our cash flow to fund acquisitions, working capital, capital expenditures, research and development efforts and other general corporate purposes;
- increase our vulnerability to and limit our flexibility in planning for, or reacting to, downturns or changes in our business and the industry in which we operate;
- restrict us from making strategic acquisitions or cause us to make non-strategic divestitures;
- expose us to the risk of increased interest rates as borrowings under the Senior Secured Credit Facility are subject to variable rates of interest;
- place us at a competitive disadvantage compared to our competitors that have less debt; and
- limit our ability to borrow additional funds.

In addition, the revolving portion of our Senior Secured Credit Facility contains a maximum total senior secured leverage ratio. The Senior Secured Credit Facility and the indenture governing the 7.125% Senior Notes also contain other negative and affirmative covenants that will limit our ability to engage in activities that may be in our long-term best interests. Our failure to comply with any of the covenants could result in an event of default which, if not cured or waived, could result in the acceleration of all of our indebtedness.

Our ability to pay regular dividends on our common stock is subject to the discretion of our Board of Directors and may be limited by our structure and statutory restrictions and restrictions imposed by the Senior Secured Credit Facility and the indenture governing the 7.125% Senior Notes as well as any future agreements.

Our Board of Directors declared a quarterly dividend of \$0.06 per share of common stock beginning in the second quarter of 2012, increased the quarterly dividend to \$0.12 per share of common stock beginning in the second quarter of 2013 and increased the quarterly dividend again to \$0.15 per share of common stock beginning in the fourth quarter of 2014. However, the payment of future dividends will be at the discretion of our Board of Directors and will depend on, among other things, our earnings, financial condition, capital requirements, level of indebtedness, statutory and contractual restrictions applying to the payment of dividends and other considerations that our Board of Directors deems relevant. The Senior Secured Credit Facility and the indenture governing the 7.125% Senior Notes also effectively limit our ability to pay dividends. As a consequence of these limitations and restrictions, we may not be able to make, or may have to reduce or eliminate, the payment of dividends on our common stock. Accordingly, you may have to sell some or all of your common stock after price appreciation in order to generate cash flow from your investment. You may not receive a gain on your investment when you sell your common stock and you may lose the entire amount of the investment. Additionally, any change in the level of our dividends or the suspension of the payment thereof could adversely affect the market price of our common stock.

To service our indebtedness, we will require a significant amount of cash and our ability to generate cash depends on many factors beyond our control.

Our ability to make cash payments on our indebtedness and to fund planned capital expenditures will depend on our ability to generate significant operating cash flow in the future. This, to a significant extent, is subject to general economic, financial, competitive, legislative, regulatory and other factors that are beyond our control.

We cannot ensure that our business will generate sufficient cash flow from operations or that future borrowings will be available to us under the Senior Secured Credit Facility in an amount sufficient to enable us to pay our indebtedness or to fund our other liquidity needs. In such circumstances, we may need to refinance all or a portion of our indebtedness on or before maturity. We cannot ensure that we will be able to refinance any of our indebtedness on commercially reasonable terms or at all. If we cannot service our indebtedness, we may have to take actions such as selling assets, seeking additional equity or reducing or delaying capital expenditures, strategic acquisitions, investments and alliances. We cannot ensure that any such actions, if necessary, could be effected on commercially reasonable terms or at all.

If we are unable to generate sufficient cash flow or are otherwise unable to obtain funds necessary to meet required payments of principal, premium, if any, and interest on our indebtedness, or if we otherwise fail to comply with the various covenants in the instruments governing our indebtedness, we could be in default under the terms of the agreements governing such indebtedness. In the event of such default, the holders of such indebtedness could elect to declare all the funds borrowed thereunder to be due and payable, together with accrued and unpaid interest, the lenders under the Senior Secured Credit Facility could elect to terminate their commitments thereunder, cease making further loans and institute foreclosure proceedings against our assets, and we could be forced into bankruptcy or liquidation. If our operating performance declines, we may in the future need to obtain waivers from the required lenders under the Senior Secured Credit Facility to avoid being in default. If we or any of our subsidiaries breach the covenants under the Senior Secured Credit Facility and seek a waiver, we may not be able to obtain a waiver from the required lenders. If this occurs, we would be in default under the Senior Secured Credit Facility, the lenders could exercise their rights, as described above, and we could be forced into bankruptcy or liquidation.

Despite current indebtedness levels, we and our subsidiaries may still be able to incur additional indebtedness, which could further exacerbate the risks associated with our substantial financial leverage.

We and our subsidiaries may be able to incur additional indebtedness in the future because the terms of our indebtedness do not fully prohibit us or our subsidiaries from doing so. Subject to covenant compliance and certain conditions, our indebtedness permits additional borrowing, including total borrowing up to \$455.1 million under the revolving portion of the Senior Secured Credit Facility. If new debt is added to our current debt levels and our subsidiaries' current debt levels, the related risks that we and they now face could intensify.

[Table of Contents](#)

ITEM 1B. Unresolved Staff Comments

None.

ITEM 2. Properties

Our world headquarters, which we own, is located at One Allison Way, Indianapolis, Indiana 46222. As of December 31, 2014, we have a total of 17 manufacturing and certain other facilities in seven countries. The following table sets forth certain information regarding these facilities.

<u>Plant</u>	<u>Location</u>	<u>Approximate Size (ft²)</u>	<u>Owned / Leased</u>	<u>Description</u>
Plant #3	Indianapolis	927,000	Own	Engineering, Operational Support
Plant #4	Indianapolis	425,900	Own	Manufacturing
Plant #6	Indianapolis	431,500	Own	Manufacturing
Plant #16	Indianapolis	391,700	Own	Manufacturing
Plant #12	Indianapolis	534,900	Own	Manufacturing
Plant #14	Indianapolis	481,100	Own	Manufacturing
Plant #15	Indianapolis	126,400	Lease	Manufacturing
Plant #17	Indianapolis	389,000	Own	Parts Distribution Center
Plant #20 Tech. Center	Indianapolis	59,000	Own	Engineering & Testing
Plant #21 Tech. Center	Indianapolis	10,000	Own	Engineering & Testing
Szentgotthard	Hungary	149,000	Own	Manufacturing & Customization
Szentgotthard	Hungary	3,900	Own	Sales & Marketing Support
Shanghai	China	38,000	Lease	Customization & Distribution
Santo Amaro/Sorocabo	Brazil	31,400	Own	Customization & Distribution
Chennai	India	258,500	Own	Manufacturing
Dubai	United Arab Emirates	16,500	Lease	Distribution
Sliedrecht	The Netherlands	37,000	Lease	Customization & Distribution

We believe all our facilities are suitable for their intended purpose, are being efficiently utilized and provide adequate capacity to meet demand for the next several years. The table above does not include sales offices located in various countries.

ITEM 3. Legal Proceedings

We are subject to various contingencies, including routine legal proceedings and claims arising out of the normal course of business. These proceedings primarily involve commercial claims, product liability claims, personal injury claims and workers' compensation claims. The outcome of these lawsuits, legal proceedings and claims cannot be predicted with certainty. Nevertheless, we believe the outcome of any of these currently existing proceedings, even if determined adversely, would not have a material adverse effect on our financial condition or results of operations.

ITEM 4. Mine Safety Disclosures

Not applicable.

PART II.

ITEM 5. Market for Registrant’s Common Equity, Related Stockholder Matters and Issuer Purchases of Equity Securities**Market Information**

Our common stock is listed on the NYSE under the symbol “ALSN.” The following table sets forth the high and low sale prices per share for our common stock on the NYSE and the dividends declared per share for each quarter for the periods indicated:

	<u>High</u>	<u>Low</u>	<u>Dividends Declared</u>
Year Ended December 31, 2014:			
First Quarter	\$31.27	\$26.41	\$ 0.12
Second Quarter	\$31.42	\$28.56	\$ 0.12
Third Quarter	\$32.21	\$28.34	\$ 0.12
Fourth Quarter	\$34.62	\$26.15	\$ 0.15
Year Ended December 31, 2013:			
First Quarter	\$24.14	\$20.13	\$ 0.06
Second Quarter	\$24.50	\$20.67	\$ 0.12
Third Quarter	\$27.48	\$22.08	\$ 0.12
Fourth Quarter	\$28.15	\$23.62	\$ 0.12

Holders

As of February 5, 2015, there were approximately 63,600 stockholders of record of our common stock, which includes the actual number of holders registered on the books of the Company and holders of shares in “street name” or persons, partnerships, associations, corporations or other entities identified in security position listings maintained by depositories.

Dividends

Our Board of Directors declared a quarterly dividend of \$0.06 per share in the first quarter of 2013, increased the quarterly dividend to \$0.12 per share beginning in the second quarter of 2013 and further increased the quarterly dividend to \$0.15 per share beginning in the fourth quarter of 2014. We expect to continue paying cash dividends on a quarterly basis; however, future dividends are subject to approval of the Board of Directors and may be adjusted as business needs or market conditions change.

Unregistered Sales of Securities

During the period covered by this Annual Report on Form 10-K, we did not offer or sell any securities that were not registered under the Securities Act of 1933, as amended (the “Securities Act”).

Issuer Purchases of Equity Securities

On October 30, 2014, our Board of Directors authorized us to repurchase up to \$500,000,000 of our common stock pursuant to a stock repurchase program (“Repurchase Program”). The terms of the Repurchase Program provide that we may repurchase shares of our common stock, from time to time depending on market conditions and corporate needs, in the open market or through privately negotiated transactions in accordance with Rule 10b-18 of the Exchange Act. Unless earlier terminated by our Board of Directors, the Repurchase Program will expire on December 31, 2016. As of December 31, 2014, \$500,000,000 remained available for stock repurchases under the Repurchase Program.

Issuances Under Equity Compensation Plans

For information regarding the securities authorized for issuance under our equity compensation plans, see Part III, Item 12 of this Annual Report on Form 10-K.

Comparative Stock Performance Graph

The information included under the heading “Comparative Stock Performance Graph” in this Item 5 of Part II of this Annual Report on Form 10-K shall not be deemed to be “soliciting material” or subject to Regulation 14A or 14C, shall not be deemed “filed” for purposes of Section 18 of the Exchange Act, or otherwise subject to the liabilities of that section, nor shall it be deemed incorporated by reference in any filing under the Securities Act or the Exchange Act.

Set forth below is a graph comparing the total cumulative returns of ALSN, the S&P 500 Index and an index of peer companies selected by us. Our peer group includes Pall Corporation, Donaldson Company Inc., Graco Inc., Roper Industries Inc., Gentex Corporation, Rockwell Automation Inc. and Sensata Technologies Holding N.V. The graph assumes \$100 was invested on March 15, 2012 in our common stock and each of the indices and that all dividends, if any, are reinvested.

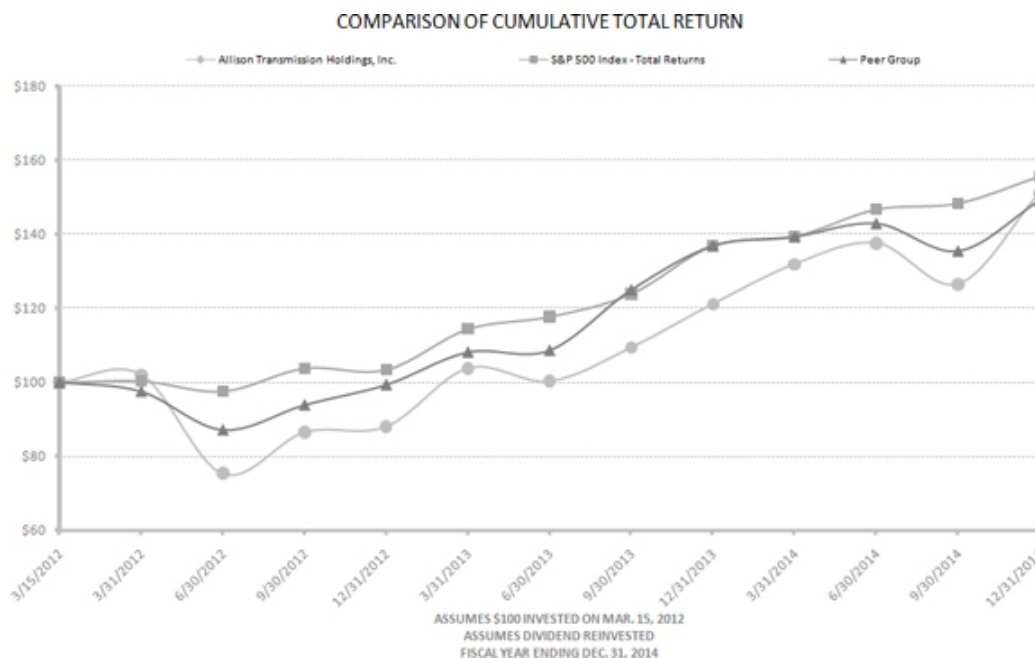

	As of March 15, 2012	As of December 31, 2012	As of December 31, 2013	As of December 31, 2014
Allison Transmission Holdings, Inc.	\$ 100.00	\$ 88.06	\$ 121.20	\$ 151.30
S&P 500 Index	100.00	103.52	137.04	155.80
Peer Group	100.00	99.32	136.95	149.34

[Table of Contents](#)

ITEM 6. Selected Financial Data

The following table sets forth certain financial information for the five years ended December 31, 2014. The following table should be read in conjunction with Part II, Item 7, “Management’s Discussion and Analysis of Financial Condition and Results of Operations” and Part II, Item 8, “Financial Statements and Supplementary Data” of this Annual Report on Form 10-K.

<i>(dollars in millions, except per share data)</i>	<u>Dec. 31, 2014</u>	<u>Dec. 31, 2013</u>	<u>Dec. 31, 2012</u>	<u>Dec. 31, 2011</u>	<u>Dec. 31, 2010</u>
Consolidated Statements of Operations:					
Net sales	\$2,127.4	\$1,926.8	\$2,141.8	\$2,162.8	\$1,926.3
Gross profit	975.9	841.9	954.3	954.5	828.2
Operating expenses:					
Selling, general and administrative expenses	344.6	334.9	419.0	409.1	384.9
Engineering — research and development	103.8	97.1	115.1	116.4	101.5
Loss associated with impairment of long-lived assets	15.4	—	—	—	—
Total operating expenses	463.8	432.0	534.1	525.5	486.4
Operating income	512.1	409.9	420.2	429.0	341.8
Other income (expense), net:					
Interest income	0.9	0.8	0.9	0.9	3.5
Interest expense	(139.3)	(133.7)	(152.1)	(218.2)	(281.0)
Premiums and expenses on tender offer for long-term debt	—	—	—	(56.9)	—
Other (expense) income, net	(5.6)	(10.9)	(52.8)	(4.2)	19.0
Total other expense, net	(144.0)	(143.8)	(204.0)	(278.4)	(258.5)
Income before income taxes	368.1	266.1	216.2	150.6	83.3
Income tax (expense) benefit	(139.5)	(100.7)	298.0	(47.6)	(53.7)
Net income	\$ 228.6	\$ 165.4	\$ 514.2	\$ 103.0	\$ 29.6
Earnings Per Share Data:					
Basic earnings per share	\$ 1.27	\$ 0.90	\$ 2.83	\$ 0.57	\$ 0.16
Weighted-average shares outstanding	179.8	184.5	182.0	181.4	181.4
Diluted earnings per share	\$ 1.25	\$ 0.88	\$ 2.76	\$ 0.56	\$ 0.16
Diluted weighted-average shares outstanding	182.3	187.9	186.2	183.3	181.4
Dividends declared per common share	\$ 0.51	\$ 0.42	\$ 0.18	\$ —	\$ —
Consolidated Balance Sheet Data:					
Cash and cash equivalents	\$ 263.0	\$ 184.7	\$ 80.2	\$ 314.0	\$ 252.2
Total assets	4,804.2	4,812.6	4,866.0	5,192.6	5,310.4
Total debt	2,520.5	2,678.3	2,820.8	3,378.6	3,671.1
Stockholders’ equity	1,397.8	1,438.8	1,356.9	821.7	741.7

ITEM 7. Management’s Discussion and Analysis of Financial Condition and Results of Operations

The following discussion contains forward-looking statements that involve risks and uncertainties. Our actual results may differ materially from those discussed in the forward looking statements as a result of various factors, including, without limitation, those set forth under Part I, Item 1A, “Risk Factors,” and other matters included elsewhere in this Annual Report on Form 10-K. The following discussion and analysis of our financial condition and results of operations should be read in conjunction with our consolidated financial statements and the notes thereto included elsewhere in this Annual Report on Form 10-K, as well as the information presented under Part II, Item 6 of this Annual Report on Form 10-K.

Overview

Allison Transmission Holdings, Inc. and its subsidiaries (“Allison,” the “Company” or “we”) design and manufacture commercial and defense fully-automatic transmissions. The business was founded in 1915 and has been headquartered in Indianapolis, Indiana since inception. Allison was an operating unit of General Motors Corporation (“Old GM”) from 1929 until 2007, when Allison once again became a stand-alone company. In March 2012, Allison began trading on the New York Stock Exchange under the symbol, “ALSN”.

We have approximately 2,700 employees and 13 different transmission product lines. Although approximately 80% percent of revenues were generated in North America in 2014, we have a global presence by serving customers in Europe, Asia, South America and Africa. We serve customers through an independent network of approximately 1,400 independent distributor and dealer locations worldwide.

Trends Impacting Our Business

Our net sales are driven by commercial vehicle production, which tends to be highly correlated to macroeconomic conditions. Our 2015 net sales guidance reflects a cautious approach given the heightened level of uncertainty and the lack of near-term visibility and confidence in the global Off-Highway end markets. Our 2015 net sales outlook also assumes a continued recovery in the North America On-Highway end market, previously considered reductions in U.S. defense spending, continued weakness in the Outside North America On-Highway end market and lower demand for North America Hybrid-Propulsion Systems for Transit Bus due to engine emissions improvements and non-hybrid alternatives.

Full Year 2014 and 2013 Net Sales by End Market (in millions)

End Market	2014 Net Sales	2013 Net Sales	% Variance
North America On-Highway	\$ 988	\$ 825	20%
North America Hybrid-Propulsion Systems for Transit Bus	93	105	(11%)
North America Off-Highway	100	39	156%
Defense	157	202	(22%)
Outside North America On-Highway	264	293	(10%)
Outside North America Off-Highway	81	88	(8%)
Service Parts, Support Equipment and Other	444	375	18%
Total Net Sales	\$ 2,127	\$ 1,927	10%

North America On-Highway end market net sales were up 20% for the year ended December 31, 2014 compared to the year ended December 31, 2013, principally driven by higher demand for Rugged Duty and Pupil Transport/Shuttle Series models.

North America Hybrid-Propulsion Systems for Transit Bus end market net sales were down 11% for the year ended December 31, 2014 compared to the year ended December 31, 2013, principally driven by lower demand due to engine emissions improvements and non-hybrid alternative technologies that generally require a fully-automatic transmission.

North America Off-Highway end market net sales were up 156% for the year ended December 31, 2014 compared to the year ended December 31, 2013, principally driven by higher demand from hydraulic fracturing applications.

Defense end market net sales were down 22% for the year ended December 31, 2014 compared to the year ended December 31, 2013, principally driven by previously considered reductions in U.S. defense spending to longer term averages experienced during periods without active conflicts.

[Table of Contents](#)

Outside North America On-Highway end market net sales were down 10% for the year ended December 31, 2014 compared to the year ended December 31, 2013, reflecting weak demand in Europe and Asia.

Outside North America Off-Highway end market net sales were down 8% for the year ended December 31, 2014 compared to the year ended December 31, 2013, principally driven by weak demand in the energy sector.

Service parts, support equipment & other end market net sales were up 18% for the year ended December 31, 2014 compared to the year ended December 31, 2013, principally driven by higher demand for North America service parts and support equipment commensurate with increased transmission unit volumes.

Key Components of our Results of Operations

Net sales

We generate our net sales primarily from the sale of transmissions, transmission parts, support equipment, defense kits, engineering services, royalties and Extended Transmission Coverage to a wide array of OEMs, distributors and the U.S. government. Sales are recorded net of provisions for customer allowances and other rebates. Engineering services are recorded as net sales in accordance with the terms of the contract. The associated costs are recorded in cost of sales. We also have royalty agreements with third parties that provide net sales as a result of joint efforts in developing marketable products.

Cost of sales

Our primary components of cost of sales are purchased parts, the overhead expense related to our manufacturing operations and direct labor associated with the manufacture and assembly of transmissions and parts. For the year ended December 31, 2014, direct material costs were approximately 68%, overhead costs were approximately 26% and direct labor costs were approximately 6% of total cost of sales. We are subject to changes in our cost of sales caused by movements in underlying commodity prices. We seek to hedge against this risk by using commodity swap contracts and LTSAs. See Part II, Item 7A, “Quantitative and Qualitative Disclosures about Market Risk—Commodity Price Risk” included in this Annual Report on Form 10-K.

Selling, general and administrative expenses

The principal components of our selling, general and administrative expenses are salaries and benefits for our office personnel, advertising and promotional expenses, product warranty expense, expenses relating to certain information technology systems and amortization of our intangibles.

Engineering — research and development

We incur costs in connection with research and development programs that are expected to contribute to future earnings. Such costs are expensed as incurred. In 2009, we were notified by the DOE that we were selected to receive matching funds up to \$62.8 million from a cost-share grant program funded by the American Recovery and Reinvestment Act for the development of hybrid-propulsion system manufacturing capacity in the U.S. (the “Grant Program”). Applicable costs associated with the Grant Program have been charged to Engineering — research and development. The DOE’s matching reimbursement is recorded to Other expense, net in the Consolidated Statements of Comprehensive Income included in Part II, Item 8, of this Annual Report on Form 10-K, or in the case of capital expenditure, as a reduction in the cost basis of the capital asset.

Critical Accounting Policies and Significant Accounting Estimates

The preparation of the consolidated financial statements in accordance with GAAP requires management to make estimates and assumptions that affect the reported amounts of some assets and liabilities and, in some instances, the reported amounts of net sales and expenses during the applicable reporting period. Differences between actual amounts and estimates are recorded in the period identified. Estimates used when evaluating revenue recognition, inventory, the impairment of goodwill and other intangibles, the impairment of long-lived assets, warranty programs, pension and post-retirement obligations, income taxes and stock-based compensation can require a significant amount of judgment, and a different set of judgments could result in changes to our reported results. A summary of our policies concerning these significant estimates is included in NOTE 2, “Summary of Significant Accounting Policies” in Part II, Item 8, of this Annual Report on Form 10-K.

Off-Balance Sheet Arrangements

We are not a party to any off-balance sheet arrangements.

Recently Adopted Accounting Pronouncements

Refer to NOTE 2, “Summary of Significant Accounting Policies” in Part II, Item 8, of this Annual Report on Form 10-K.

Non-GAAP Financial Measures

We use Adjusted net income to measure our overall profitability because we believe it better reflects our cash flow generation by capturing the actual cash interest paid and cash taxes paid rather than our interest expense and tax expense as calculated under accounting principles generally accepted in the United States of America (“GAAP”) and excludes the impact of the non-cash annual amortization of certain intangible assets and other certain non-recurring items. We use Adjusted EBITDA, Adjusted EBITDA excluding technology-related license expenses, Adjusted EBITDA margin, Adjusted EBITDA margin excluding technology-related license expenses and Adjusted free cash flow to evaluate and control our cash operating costs and to measure our operating profitability. We believe the presentation of Adjusted net income, Adjusted EBITDA, Adjusted EBITDA excluding technology-related license expenses, Adjusted EBITDA margin, Adjusted EBITDA margin excluding technology-related license expenses and Adjusted free cash flow enhances our investors’ overall understanding of the financial performance and cash flow of our business.

You should not consider Adjusted net income, Adjusted EBITDA, Adjusted EBITDA excluding technology-related license expenses, Adjusted EBITDA margin and Adjusted EBITDA margin excluding technology-related license expenses as an alternative to net income, determined in accordance with GAAP, as an indicator of operating performance. You should not consider Adjusted free cash flow as an alternative to net cash provided by operating activities, determined in accordance with GAAP, as an indicator of our cash flow.

A directly comparable GAAP measure to Adjusted net income, Adjusted EBITDA and Adjusted EBITDA excluding technology-related license expenses is Net income. A directly comparable GAAP measure to Adjusted free cash flow is Net cash provided by operating activities. The following is a reconciliation of Net income to Adjusted net income, Adjusted EBITDA, Adjusted EBITDA excluding technology-related license expenses, Adjusted EBITDA margin and Adjusted EBITDA margin excluding technology-related license expenses, and a reconciliation of Net cash provided by operating activities to Adjusted free cash flow:

(unaudited, in millions)	For the years ended December 31,		
	2014	2013	2012
Net income	\$ 228.6	\$ 165.4	\$ 514.2
plus:			
Interest expense, net	138.4	132.9	151.2
Cash interest expense	(140.0)	(159.2)	(167.3)
Income tax expense (benefit)	139.5	100.7	(298.0)
Cash income taxes	(5.0)	(3.8)	(10.7)
Amortization of intangible assets	98.8	105.3	150.0
Loss associated with impairment of long-lived assets (a)	15.4	—	—
Technology-related investment expense (b)	2.0	5.0	14.4
Public offering expenses (c)	1.4	1.6	6.1
Fee to terminate services agreement (d)	—	—	16.0
Adjusted net income	\$ 479.1	\$ 347.9	\$ 375.9
Cash interest expense	140.0	159.2	167.3
Cash income taxes	5.0	3.8	10.7
Depreciation of property, plant and equipment	93.8	98.7	102.5
Unrealized loss on foreign exchange (e)	5.2	2.3	0.1
Dual power inverter module extended coverage (f)	1.0	(2.4)	9.4
Unrealized (gain) loss on commodity hedge contracts (g)	(1.0)	1.5	(1.0)
Restructuring charge (h)	0.7	1.0	—
Loss on repayments and repurchases of long-term debt (i)	0.5	0.8	22.1
Benefit plan re-measurement (j)	—	—	2.3
UAW Local 933 contract signing bonus (k)	—	—	8.8
Other (l)	14.7	13.8	7.0
Adjusted EBITDA	\$ 739.0	\$ 626.6	\$ 705.1
Adjusted EBITDA excluding technology-related licenses expenses (m)	\$ 745.1	\$ 632.6	\$ 717.1
Net sales	\$2,127.4	\$1,926.8	\$2,141.8
Adjusted EBITDA margin	34.7%	32.5%	32.9%
Adjusted EBITDA margin excluding technology-related licenses expenses (m)	35.0%	32.8%	33.5%
Net cash provided by operating activities	\$ 556.9	\$ 453.5	\$ 497.5
(Deductions) or additions to reconcile to Adjusted free cash flow:			
Additions of long-lived assets	(64.1)	(74.4)	(123.9)
Excess tax benefit from stock-based compensation (n)	24.6	13.7	5.3
Fee to terminate services agreement (d)	—	—	16.0
Technology-related license expenses (m)	6.1	6.0	12.0
Adjusted free cash flow	\$ 523.5	\$ 398.8	\$ 406.9

Table of Contents

- (a) Represents a charge associated with the impairment of long-lived assets related to the production of the H3000 and H4000 hybrid-propulsion systems.
- (b) Represents a charge (recorded in Other expense, net) for investments in co-development agreements to expand our position in transmission technologies.
- (c) Represents fees and expenses (recorded in Other expense, net) related to our secondary offerings in September 2014, June 2014, April 2014, February 2014, December 2013, November 2013 and August 2013, proposed secondary offering in April 2013 and initial public offering in March 2012.
- (d) Represents a payment (recorded in Other expense, net) to terminate a services agreement with the Carlyle Group and Onex Corporation (collectively, the “Sponsors”).
- (e) Represents losses (recorded in Other expense, net) on the mark-to-market of our foreign currency hedge contracts and on intercompany financing transactions related to investments in plant assets for our India facility.
- (f) During 2014, 2013 and 2012, we conducted a review of the Dual Power Inverter Module (“DPIM”) extended coverage program resulting in an increase of the DPIM liability in 2014, a reduction of the DPIM liability in 2013 and an increase of the DPIM liability in 2012, partially offset by a respective increase, reduction and increase of the associated General Motors Company (“GM”) receivable (recorded in Selling, general and administrative expenses). The total liability and GM receivable will continue to be reviewed for any changes in estimate as additional claims data and field information become available.
- (g) Represents (gains) losses (recorded in Other expense, net) on the mark-to-market of our commodity hedge contracts.
- (h) Represents a charge (recorded in Selling, general and administrative, and Engineering – research and development) related to employee headcount reductions in the second quarter of 2014 and second quarter of 2013.
- (i) Represents losses (recorded in Other expense, net) realized on the repayments and repurchases of Allison Transmission, Inc.’s (“ATI”), our wholly owned subsidiary, long-term debt.
- (j) Represents a settlement charge (recorded in Other expense, net) related to the settlement of pension obligations for certain qualified hourly employees from our hourly defined benefit pension plan to GM’s pension plan as part of the asset purchase agreement dated June 28, 2007.
- (k) Represents a bonus (recorded in Cost of sales, Selling, general and administrative expenses, and Engineering – research and development) to eligible employees recorded in the fourth quarter of 2012 as a result of UAW Local 933 – represented employees ratifying a labor contract effective November 2012 through November 2017.
- (l) Represents employee stock compensation expense (recorded in Cost of sales, Selling, general and administrative expenses, and Engineering – research and development) and service fees paid to the Sponsors (recorded in Selling, general and administrative expenses).
- (m) Represents payments (recorded in Engineering – research and development) for licenses to expand our position in transmission technologies.
- (n) Represents the amount of tax benefit (recorded in Income tax expense) related to stock-based compensation adjusted from cash flows from operating activities to cash flows from financing activities.

Results of Operations

The following tables set forth certain financial information for the years ended December 31, 2014 and 2013 and for the years ended December 31, 2013 and 2012. The following tables and discussion should be read in conjunction with the information contained in our consolidated financial statements and the notes thereto included in Part II, Item 8 of this Annual Report on Form 10-K.

Comparison of years ended December 31, 2014 and 2013

<i>(dollars in millions)</i>	Years ended December 31,			
	2014	% of net sales	2013	% of net sales
Net sales	\$2,127.4	—	\$1,926.8	—
Gross profit	975.9	46%	841.9	44%
Operating expenses:				
Selling, general and administrative expenses	344.6	16	334.9	17
Engineering — research and development	103.8	5	97.1	5
Loss associated with impairment of long-lived assets	15.4	1	—	—
Total operating expenses	463.8	22	432.0	22
Operating income	512.1	24	409.9	22
Other expense, net:				
Interest expense, net	(138.4)	(7)	(132.9)	(7)
Other expense, net	(5.6)	(0)	(10.9)	(1)
Total other expense, net	(144.0)	(7)	(143.8)	(8)
Income before income taxes	368.1	17	266.1	14
Income tax expense	(139.5)	(7)	(100.7)	(5)
Net income	\$ 228.6	10%	\$ 165.4	9%

Net sales

Net sales for the year ended December 31, 2014 were \$2,127.4 million compared to \$1,926.8 million for the year ended December 31, 2013, an increase of 10%. The increase was principally driven by a \$163.0 million, or 20%, increase in net sales of North American on-highway products principally driven by higher demand from Rugged Duty Series and Pupil Transport/Shuttle Series models, a \$69.0 million, or 18%, increase in net sales of parts and other products principally driven by higher demand for North American service parts and support equipment commensurate with increased transmission unit volumes, and a \$61.0 million, or 156%, increase in net sales of North American off-highway products principally driven by higher demand from hydraulic fracturing applications, partially offset by a \$45.0 million, or 22%, decrease in net sales of defense products due to lower U.S. defense spending, a \$29.0 million, or 10%, decrease in net sales of Outside North America on-highway products principally driven by weakness in Europe and Asia, a \$12.0 million, or 11%, decrease in net sales of North America hybrid-propulsion systems for transit buses principally driven by lower demand due to engine emissions improvements and non-hybrid alternatives (e.g. xNG), and a \$7.0 million, or 8%, decrease in net sales of Outside North America off-highway products principally driven by lower demand from the energy sector. See “Trends Impacting Our Business” above for additional information on net sales by end markets.

Gross profit

Gross profit for the year ended December 31, 2014 was \$975.9 million compared to \$841.9 million for the year ended December 31, 2013, an increase of 16%. The increase was principally driven by \$122.0 million related to increased net sales, \$20.0 million of price increases on certain products and \$3.0 million of favorable foreign exchange, partially offset by \$5.8 million of higher incentive compensation expense and \$5.2 million of higher manufacturing expense commensurate with increased net sales.

Selling, general and administrative expenses

Selling, general and administrative expenses for the year ended December 31, 2014 were \$344.6 million compared to \$334.9 million for the year ended December 31, 2013, an increase of 3%. The increase was principally driven by \$7.1 million of higher incentive compensation expense, increased global commercial spending activities, a \$2.4 million favorable adjustment in 2013 related to the DPIM extended coverage program and a \$1.0 million unfavorable adjustment in 2014 related to the DPIM extended coverage program, partially offset by \$6.5 million of lower intangible asset amortization.

Engineering — research and development

Engineering expenses for the year ended December 31, 2014 were \$103.8 million compared to \$97.1 million for the year ended December 31, 2013, an increase of 7%. The increase was principally driven by increased spending on product initiatives and \$2.7 million of higher incentive compensation expense.

Loss associated with impairment of long-lived assets

During 2014, we reviewed certain of our long-lived assets related to the production of the H3000 and H4000 hybrid-propulsion systems, resulting in a \$15.4 million loss recorded for the year ended December 31, 2014. The loss included approximately \$1.7 million of accrued expenses related to the impairment of the long-lived assets.

Interest expense, net

Interest expense, net for the year ended December 31, 2014 was \$138.4 million compared to \$132.9 million for the year ended December 31, 2013, an increase of 4%. The increase was principally driven by \$30.8 million of less favorable mark-to-market adjustments for interest rate derivatives, partially offset by \$12.3 million of lower interest expense as a result of the maturity of \$950.0 million of interest rate derivatives, \$5.2 million of lower interest expense as a result of debt repayments, \$4.7 million of lower interest expense related to lower interest rates and \$2.8 million of lower amortization of deferred financing fees.

Other expense, net

Other expense, net for the year ended December 31, 2014 was \$5.6 million compared to \$10.9 million for the year ended December 31, 2013, a decrease of 49%. The decrease in expense was principally driven by \$4.5 million of lower expenses related to unrealized and realized losses on derivative contracts, \$3.0 million of lower technology-related investment impairment expense, a \$2.0 million gain related to the negotiation of a commercial agreement, \$1.4 million of lower expenses related to foreign exchange losses, \$0.3 million of lower expenses related to debt repayments, and \$0.2 million of lower public offering fees and expenses, partially offset by \$3.1 million of increased foreign exchange losses on intercompany financing, \$2.6 million of lower Grant Program income and \$0.4 million of lower miscellaneous income.

Income tax expense

Income tax expense for the year ended December 31, 2014 was \$139.5 million compared to \$100.7 million for the year ended December 31, 2013, resulting in an effective tax rate of 38% for each of the years ended December 31, 2014 and December 31, 2013.

Comparison of years ended December 31, 2013 and 2012

<i>(dollars in millions)</i>	Years ended December 31,			
	2013	% of net sales	2012	% of net sales
Net sales	\$1,926.8	—	\$2,141.8	—
Gross profit	841.9	44%	954.3	45%
Operating expenses:				
Selling, general and administrative expenses	334.9	17	419.0	20
Engineering — research and development	97.1	5	115.1	5
Total operating expenses	432.0	22	534.1	25
Operating income	409.9	22	420.2	20
Other expense, net:				
Interest expense, net	(132.9)	(7)	(151.2)	(7)
Other expense, net	(10.9)	(1)	(52.8)	(2)
Total other expense, net	(143.8)	(8)	(204.0)	(9)
Income before income taxes	266.1	14	216.2	11
Income tax (expense) benefit	(100.7)	(5)	298.0	14
Net income	\$ 165.4	9%	\$ 514.2	25%

Net sales

Net sales for the year ended December 31, 2013 were \$1,926.8 million compared to \$2,141.8 million for the year ended December 31, 2012, a decrease of 10%. The decrease was principally driven by a \$144.0 million, or 53%, decrease in net sales of global off-highway products principally driven by lower demand from North America natural gas fracturing applications and lower global demand in the mining sector, a \$103.0 million, or 34%, decrease in net sales of defense products due to lower U.S. defense spending and a \$10.0 million, or 9%, decrease in net sales of North America hybrid-propulsion systems for transit buses principally driven by lower demand due to engine emissions improvements and non-hybrid alternatives (e.g. xNG), partially offset by a \$27.0 million, or 8%, increase in net sales of parts and other products, and a \$15.0 million, or 1%, increase in net sales of global on-highway products. See “Trends Impacting Our Business” above for additional information on net sales by end markets.

Gross profit

Gross profit for the year ended December 31, 2013 was \$841.9 million compared to \$954.3 million for the year ended December 31, 2012, a decrease of 12%. The decrease was principally driven by \$132.0 million related to decreased sales, partially offset by \$7.7 million related to the fourth quarter 2012 UAW Local 933 contract signing bonus, \$6.0 million of favorable foreign exchange and \$4.0 million of favorable manufacturing performance.

Selling, general and administrative expenses

Selling, general and administrative expenses for the year ended December 31, 2013 were \$334.9 million compared to \$419.0 million for the year ended December 31, 2012, a decrease of 20%. The decrease was principally driven by \$44.7 million of lower intangible asset amortization, a \$9.4 million charge in 2012 related to the DPIM extended coverage program, \$8.0 million of unfavorable product warranty adjustments in 2012 from prior period estimates, a \$2.4 million favorable adjustment in 2013 related to the DPIM extended coverage program, \$1.0 million related to the fourth quarter 2012 UAW Local 933 contract signing bonus and reduced global commercial spending activities, partially offset by \$6.0 million of higher stock compensation expense.

Engineering - research and development

Engineering expenses for the year ended December 31, 2013 were \$97.1 million compared to \$115.1 million for the year ended December 31, 2012, a decrease of 16%. The decrease was principally driven by \$12.0 million of technology-related license expenses in 2012 to expand our position in transmission technologies, \$0.1 million related to the fourth quarter 2012 UAW Local 933 contract signing bonus, lower product initiative spending and reduced global spending activities, partially offset by \$6.0 million of technology-related license expenses in 2013 to further expand our position in transmission technologies.

Interest expense, net

Interest expense, net for the year ended December 31, 2013 was \$132.9 million compared to \$151.2 million for the year ended December 31, 2012, a decrease of 12%. The decrease was principally driven by \$14.4 million of lower interest expense as a result of debt repayments and purchases, an \$8.8 million decrease in mark-to-market expense for our interest rate derivatives, \$3.8 million of lower interest expense as a result of a decrease in effective interest rate swaps and \$3.4 million of lower amortization of deferred financing fees, partially offset by \$9.0 million of higher interest expense as a result of higher interest rates on the Senior Secured Credit Facility, \$3.0 million of higher interest expense related to higher interest rates on our effective interest rate swaps and \$0.1 million of lower interest income.

Other expense, net

Other expense, net for the year ended December 31, 2013 was \$10.9 million compared to \$52.8 million for the year ended December 31, 2012, a decrease of 79%. The decrease in expense was principally driven by \$21.3 million of lower premiums and expenses related to payments on and redemptions of long-term debt, a \$16.0 million payment in 2012 to terminate the services agreement with the Sponsors, \$9.4 million of lower technology-related investment impairment expense, \$4.5 million of lower public offering expenses, \$2.3 million related to the hourly pension plan settlement in 2012 and \$0.7 million of reduced miscellaneous expenses, partially offset by \$3.9 million of higher expenses related to unrealized and realized losses on derivative contracts, \$2.1 million of higher unfavorable foreign exchange and \$6.3 million of lower Grant Program income.

Income tax (expense) benefit

Income tax expense for the year ended December 31, 2013 was (\$100.7) million compared to an income tax benefit of \$298.0 million for the year ended December 31, 2012, resulting in an effective tax rate of (38%) for the year ended December 31, 2013 versus an effective tax rate of 138% for the year ended December 31, 2012. The change in effective tax rate was principally driven by the release of the domestic valuation allowance on our deferred tax assets in the second quarter of 2012.

Liquidity and Capital Resources

We generate cash primarily from our operating activities to fund our operating, investing and financing activities. Our principal uses of cash are operating expenses, capital expenditures, debt service, stock repurchases, dividends on common stock and working capital needs. We had total available cash and cash equivalents of \$263.0 million and \$184.7 million as of December 31, 2014 and 2013, respectively. Of the available cash and cash equivalents, approximately \$208.0 million and \$179.7 million were deposited in operating accounts while approximately \$55.0 million and \$5.0 million were invested in U.S. government backed securities as of December 31, 2014 and 2013, respectively.

As of December 31, 2014, the total of cash and cash equivalents held by foreign subsidiaries was \$35.3 million, the majority of which was located in Europe, Hungary and China. The geographic location of our cash aligns with our business growth strategy. We manage our worldwide cash requirements considering available funds among the subsidiaries through which we conduct our business and the cost effectiveness with which those funds can be accessed. As a result, we do not anticipate any local liquidity restrictions to preclude us from funding our targeted expectations or operating needs with local resources.

If we distribute our foreign cash balance to the U.S. or to other foreign subsidiaries, we could be required to accrue and pay U.S. taxes. For example, we would be required to accrue and pay additional U.S. taxes if we repatriate cash from certain foreign subsidiaries whose earnings we have asserted are permanently reinvested outside of the U.S. Foreign earnings for which we assert permanent reinvestment outside the U.S. consists primarily of earnings of our Europe and China subsidiaries. We currently do not foresee a need to repatriate any earnings from these subsidiaries for which we have asserted permanent reinvestment.

Our liquidity requirements are significant, primarily due to our debt service requirements. As of December 31, 2014, the Company had \$283.6 million of indebtedness associated with ATI's Senior Secured Credit Facility Term B-2 Loan due 2017 ("Term B-2 Loan") and \$1,765.6 million of indebtedness associated with ATI's Senior Secured Credit Facility Term B-3 Loan due 2019 ("Term B-3 Loan," and together with the Term B-2 Loan and revolving credit facility, the "Senior Secured Credit Facility"). The Company also had indebtedness of \$471.3 million of ATI's 7.125% senior cash pay notes due May 2019 ("7.125% Senior Notes").

Our ability to make payments on and to refinance our indebtedness, and to fund planned capital expenditures will depend on our ability to generate cash in the future. This is subject to general economic, financial, competitive, legislative, regulatory and other factors that may be beyond our control. We made principal payments of \$157.6 million, \$142.4 million and \$245.4 million on the Senior Secured Credit Facility for the years ended December 31, 2014, 2013 and 2012, respectively.

The Senior Secured Credit Facility also provides for \$465.0 million in revolving credit borrowings, net of an allowance for up to \$75.0 million in outstanding letters of credit commitments. During 2014, the maximum amount outstanding at any time on the revolving credit facility was \$40.0 million, and all balances were repaid within the quarter they were borrowed. As of December 31, 2014, we had no outstanding borrowings on our revolving credit facility. Additionally within the terms of the Senior Secured Credit Facility, a senior secured leverage ratio at or below 3.50x results in the elimination of excess cash flow payments on the Senior Secured Credit Facility for the applicable year. The Senior Secured Credit Facility provides certain financial incentives based on our total leverage ratio. A total leverage ratio at or below 4.00x results in a 25 basis point reduction to the applicable margin on our revolving credit facility, and a total leverage ratio at or below 3.50x results in a 12.5 basis point reduction to the revolving credit facility commitment fee and an additional 25 basis point reduction to the applicable margin on our revolving credit facility. A total leverage ratio at or below 3.25x results in a 25 basis point reduction to the applicable margin on our Term B-3 Loan. These reductions would remain in effect as long as we achieve a total leverage ratio at or below the related threshold. As of December 31, 2014, the total leverage ratio was 3.05x.

In addition to the maximum total senior secured leverage ratio for the revolving portion of the Senior Secured Credit Facility, the Senior Secured Credit Facility and the indenture governing the 7.125% Senior Notes include, among other things, customary restrictions (subject to certain exceptions) on our ability to incur certain indebtedness or liens, make certain investments, declare or pay certain dividends, or repurchase shares of our common stock. As of December 31, 2014, we are in compliance with all covenants under the Senior Secured Credit Facility.

Prior to May 15, 2015, we may redeem some or all of our 7.125% Senior Notes by paying the applicable "make-whole" premium. At any time on or after May 15, 2015, we may redeem some or all of the 7.125% Senior Notes at specified redemption prices in the governing indenture as follows:

<u>Year</u>	<u>Percentage</u>
2015	103.563%
2016	101.781%
2017 and thereafter	100.000%

[Table of Contents](#)

Our credit ratings are reviewed regularly by major debt ratings agencies such as Standard and Poor's, Moody's Investors Service and Fitch Ratings. In January 2015, Standard and Poor's raised the issue ratings and revised recovery ratings. The rating of the Senior Secured Credit Facility was raised to BB+ from BB, and the rating of the 7.125% Senior Notes was raised to B+ from B.

In connection with secondary public offerings of our common stock held by investment funds affiliated with the Sponsors, we repurchased from the underwriters 5,000,000 shares of common stock in June 2014 and 3,428,179 shares in February 2014 at the prices paid by the underwriters for a total cost of \$249.8 million and subsequently retired those shares.

On October 30, 2014, our Board of Directors authorized us to purchase up to \$500.0 million of our common stock under a stock repurchase program. We anticipate that future repurchases under this program will be an ongoing use of cash.

The following table shows our sources and uses of funds for the years ended December 31, 2014, 2013 and 2012 (in millions):

<i>Statement of Cash Flows Data</i>	<i>Years ended December 31,</i>		
	<i>2014</i>	<i>2013</i>	<i>2012</i>
Cash flows from operating activities	\$ 556.9	\$ 453.5	\$ 497.5
Cash flows used for investing activities	(67.9)	(81.5)	(138.7)
Cash flows used for financing activities	(424.1)	(277.5)	(593.5)

Generally, cash provided by operating activities has been adequate to fund our operations. Due to fluctuations in our cash flows and the growth in our operations, it may be necessary from time to time in the future to borrow under the Senior Secured Credit Facility to meet cash demands. We anticipate cash provided by operating activities, cash and cash equivalents and borrowing capacity under the Senior Secured Credit Facility will be sufficient to meet our cash requirements for the next twelve months.

Cash provided by operating activities

Operating activities for the year ended December 31, 2014 generated \$556.9 million of cash compared to \$453.5 million for the year ended December 31, 2013. The increase was principally driven by increased net sales, lower inventories, lower cash interest expense and higher other liabilities, net, partially offset by higher accounts receivable commensurate with increased net sales and increased excess tax benefit from stock-based compensation.

Operating activities for the year ended December 31, 2013 generated \$453.5 million of cash compared to \$497.5 million for the year ended December 31, 2012. The decrease was principally driven by decreased net sales, higher accounts receivable principally driven by lower accounts receivable at the end of 2012 as a result of earlier than expected receipts, lower other liabilities, net, and increased excess tax benefit from stock-based compensation, partially offset by higher accounts payable principally driven by lower accounts payable at the end of 2012 as a result of labor negotiations planning, decreased spending commensurate with reduced global commercial and product initiatives spending, lower cash interest expense and lower cash income taxes.

Cash used for investing activities

Investing activities for the year ended December 31, 2014 used \$67.9 million of cash compared to \$81.5 million for the year ended December 31, 2013. The decrease was principally driven by a decrease of \$10.3 million in capital expenditures and a decrease of \$3.0 million in investments in technology-related initiatives. The decrease in capital expenditures was principally driven by lower product initiatives spending, partially offset by increased investments in productivity and replacement programs.

Investing activities for the year ended December 31, 2013 used \$81.5 million of cash compared to \$138.7 million for the year ended December 31, 2012. The decrease was principally driven by a decrease of \$49.5 million in capital expenditures and a decrease of \$5.6 million in investments in technology-related initiatives. The decrease in capital expenditures was principally driven by the 2012 expansion of our India facility and lower product initiatives spending.

Cash used for financing activities

Financing activities for the year ended December 31, 2014 used \$424.1 million of cash compared to \$277.5 million for the year ended December 31, 2013. The increase was principally driven by \$150.3 million related to increased repurchases of our common stock in connection with the June 2014 and February 2014 secondary offerings by investment funds affiliated with the Sponsors, \$15.2 million of increased payments on the Senior Secured Credit Facility, \$14.5 million of increased dividend payments and \$4.8 million of higher taxes paid related to net share settlement of equity awards, partially offset by \$14.0 million of decreased debt financing fees, \$13.3 million of increased proceeds from the exercise of stock options and \$10.9 million of increased excess tax benefit from stock based compensation.

[Table of Contents](#)

Financing activities for the year ended December 31, 2013 used \$277.5 million of cash compared to \$593.5 million for the year ended December 31, 2012. The decrease was principally driven by 2012 redemptions of \$326.9 million of ATT's 11.0% senior cash pay notes due November 2015, \$103.0 million of decreased principal payments on the Senior Secured Credit Facility, \$17.3 million of increased proceeds from the exercise of stock options, \$8.4 million of increased tax benefits from stock based compensation and \$5.3 million of decreased debt financing fees, partially offset by \$99.5 million related to the repurchase of our common stock in connection with the August 2013 secondary offering by the Sponsors and \$44.3 million of increased dividend payments.

Contractual Obligations, Contingent Liabilities and Commitments

The following table summarizes our contractual obligations as of December 31, 2014 (dollars in millions):

	Payments due by period				
	Total	Less than 1 year	1-3 years	3-5 years	More than 5 years
7.125% Senior Notes(1)	\$ 622.3	\$ 33.5	\$ 67.2	\$ 521.6	\$ —
Senior Secured Credit Facility(2)	2,393.4	92.1	462.1	1,839.2	—
Operating leases	12.5	4.6	4.5	1.4	2.0
Pension & OPEB liabilities(3)	21.1	4.8	10.7	5.6	see (3) below
Total(4)	<u>\$3,049.3</u>	<u>\$ 135.0</u>	<u>\$544.5</u>	<u>\$2,367.8</u>	<u>\$ 2.0</u>

(1) 7.125% Senior Notes include principal and interest payments based on a fixed interest rate of 7.125%.

(2) Senior Secured Credit Facility includes principal payments and estimated interest payments excluding the effects of our interest rate swaps. A portion of the interest is at a variable rate and for the purposes of this table has been calculated using LIBOR as of December 31, 2014, plus the applicable margin of each loan, resulting in an applied rate of 2.92% for Term B-2 Loan and 3.75% for Term B-3 Loan. Actual payments will vary.

(3) Estimated pension funding and post-retirement benefit payments are based on an increasing discount rate and effective interest rate for funding purposes between 4.5% - 5.5%. Pension funding and post-retirement benefit payments are excluded from the table beyond year 5, though we expect funding and payments to continue beyond year 5. See NOTE 13 of Notes to Consolidated Financial Statements included in Part II, Item 8, of this Annual Report on Form 10-K for the funding status of our pension plans and other post-retirement plan as of December 31, 2014.

(4) Estimated warranty obligations, sales allowance programs and defense price reduction reserves, which total \$83.6 million, \$25.5 million and \$63.1 million, respectively, as of December 31, 2014 have been excluded from this table as timing of any payments are uncertain.

ITEM 7A. Quantitative and Qualitative Disclosures About Market Risk

Our exposure to market risk consists of changes in interest rates, foreign currency rate fluctuations and movements in commodity prices.

Interest Rate Risk

We are subject to interest rate market risk in connection with a portion of our long-term debt. Our principal interest rate exposure relates to outstanding amounts under our Senior Secured Credit Facility. Our Senior Secured Credit Facility provides for variable rate borrowings of up to \$2,504.3 million including \$455.1 million under our revolving credit facility, net of \$9.9 million of letters of credit. A one-eighth percent change in assumed interest rates for the Senior Secured Credit Facility, if fully drawn, as of December 31, 2014 would have an impact of approximately \$1.0 million on interest expense assuming the 1.00% LIBOR floor is in effect for our Term B-3 Loan. Should LIBOR exceed 1.00%, a one-eighth percent change in assumed interest rates for the Senior Secured Credit Facility, if fully drawn, as of December 31, 2014 would have an impact of approximately \$3.0 million on interest expense. As of December 31, 2014, we had no outstanding borrowings against the revolving credit facility.

From time to time, we enter into interest rate swap agreements to hedge our variable interest rate debt. Below is a list of our interest rate swaps as of December 31, 2014:

	<u>Counterparty</u>	<u>Effective Date</u>	<u>Notional Amount (in millions)</u>	<u>LIBOR Fixed Rate</u>
Interest Rate Swap L	Barclays	Aug 2016-Aug 2019	\$ 75.0	3.44%*
Interest Rate Swap M	JP Morgan	Aug 2016-Aug 2019	\$ 100.0	3.43%*
Interest Rate Swap N	Bank of America	Aug 2016-Aug 2019	\$ 75.0	3.37%*
Interest Rate Swap O	Deutsche Bank	Aug 2016-Aug 2019	\$ 75.0	3.19%*
Interest Rate Swap P	Barclays	Aug 2016-Aug 2019	\$ 75.0	3.08%*
Interest Rate Swap Q	Barclays	Aug 2016-Aug 2019	\$ 50.0	2.99%*
Interest Rate Swap R	Deutsche Bank	Aug 2016-Aug 2019	\$ 50.0	2.98%*
Interest Rate Swap S	Deutsche Bank	Aug 2016-Aug 2019	\$ 50.0	2.73%*
Interest Rate Swap T	Bank of America	Aug 2016-Aug 2019	\$ 75.0	2.74%*
Interest Rate Swap U	Fifth Third Bank	Aug 2016-Aug 2019	\$ 50.0	2.66%*
Interest Rate Swap V	Fifth Third Bank	Aug 2016-Aug 2019	\$ 50.0	2.60%*
Interest Rate Swap W	Fifth Third Bank	Aug 2016-Aug 2019	\$ 25.0	2.40%*

* includes LIBOR floor of 1.00%

We are exposed to increased interest expense if a counterparty defaults. Refer to NOTE 7 and NOTE 8 of Notes to Consolidated Financial Statements included in Part II, Item 8, of this Annual Report on Form 10-K.

Exchange Rate Risk

While our net sales and costs are denominated primarily in U.S. Dollars, net sales, costs, assets and liabilities are generated in other currencies including Japanese Yen, Euro, Indian Rupee, Brazilian Real, Chinese Yuan Renminbi, Canadian Dollar and Hungarian Forint. The expansion of our business outside North America may further increase the risk that cash flows resulting from these activities may be adversely affected by changes in currency exchange rates. As of December 31, 2014, we hold hedging contracts in the Japanese Yen, which are intended to hedge either known or forecasted cash flow payments denominated in the currency. We do not hold financial instruments for trading or speculative purposes.

Assuming current levels of foreign currency transactions, a 10% aggregate increase or decrease in the Japanese Yen, Euro, Indian Rupee, Chinese Yuan Renminbi and Canadian Dollar would correspondingly change our earnings by an estimated \$5 million per year. This includes the partial offset of our hedging contracts described above. All other exposure to foreign currencies is considered immaterial.

Commodity Price Risk

We are subject to changes in our cost of sales caused by movements in underlying commodity prices. Approximately two-thirds of our cost of sales consists of purchased components with significant raw material content. A substantial portion of the purchased parts are made of aluminum and steel. The cost of aluminum parts include an adjustment factor on future purchases for fluctuations in aluminum prices based on accepted industry indices. In addition, a substantial amount of steel-based contracts also include an index-based component. As our costs change, we are able to pass through a portion of the changes in commodity prices to certain of our customers according to our LTSAs. We historically have not entered into long-term purchase contracts related to the purchase of aluminum and steel. We currently hold financial forward contracts that are intended to hedge forecasted aluminum purchases. Based on our forecasted demand for 2015 and 2016, as of December 31, 2014, the hedge contracts cover approximately 30% and 16% of our aluminum requirements, respectively. We do not hold financial instruments for trading or speculative purposes.

Assuming current levels of commodity purchases, a 10% increase or decrease in the price of aluminum and steel would correspondingly change our earnings by approximately \$1 million and \$4 million per year, respectively. This includes the partial offset of our hedging contracts described above.

Many of our LTSAs have incorporated a cost-sharing arrangement related to potential future commodity price fluctuations. Our hedging policy is that we only hedge for our exposure and do not hedge any portion of the customers' exposure. For purposes of the sensitivity analysis above, the impact of these cost-sharing arrangements have not been included.

ITEM 8. Financial Statements and Supplementary Data

Report of Independent Registered Public Accounting Firm

To the Board of Directors and Stockholders of
Allison Transmission Holdings, Inc.

In our opinion, the accompanying consolidated balance sheets and the related consolidated statements of comprehensive income, of stockholders' equity and of cash flows present fairly, in all material respects, the financial position of Allison Transmission Holdings, Inc. and its subsidiaries at December 31, 2014 and December 31, 2013, and the results of their operations and their cash flows for each of the three years in the period ended December 31, 2014 in conformity with accounting principles generally accepted in the United States of America. In addition, in our opinion, the financial statement schedule listed in the index appearing under Item 15(a)(2) presents fairly, in all material respects, the information set forth therein when read in conjunction with the related consolidated financial statements. Also in our opinion, the Company maintained, in all material respects, effective internal control over financial reporting as of December 31, 2014, based on criteria established in Internal Control - Integrated Framework (2013) issued by the Committee of Sponsoring Organizations of the Treadway Commission (COSO). The Company's management is responsible for these financial statements and financial statement schedule, for maintaining effective internal control over financial reporting and for its assessment of the effectiveness of internal control over financial reporting, included in Management's Report on Internal Control Over Financial Reporting appearing under Item 9A. Our responsibility is to express opinions on these financial statements, on the financial statement schedule, and on the Company's internal control over financial reporting based on our audits (which were integrated audits in 2013 and 2014). We conducted our audits in accordance with the standards of the Public Company Accounting Oversight Board (United States). Those standards require that we plan and perform the audits to obtain reasonable assurance about whether the financial statements are free of material misstatement and whether effective internal control over financial reporting was maintained in all material respects. Our audits of the financial statements included examining, on a test basis, evidence supporting the amounts and disclosures in the financial statements, assessing the accounting principles used and significant estimates made by management, and evaluating the overall financial statement presentation. Our audit of internal control over financial reporting included obtaining an understanding of internal control over financial reporting, assessing the risk that a material weakness exists, and testing and evaluating the design and operating effectiveness of internal control based on the assessed risk. Our audits also included performing such other procedures as we considered necessary in the circumstances. We believe that our audits provide a reasonable basis for our opinions.

A company's internal control over financial reporting is a process designed to provide reasonable assurance regarding the reliability of financial reporting and the preparation of financial statements for external purposes in accordance with generally accepted accounting principles. A company's internal control over financial reporting includes those policies and procedures that (i) pertain to the maintenance of records that, in reasonable detail, accurately and fairly reflect the transactions and dispositions of the assets of the company; (ii) provide reasonable assurance that transactions are recorded as necessary to permit preparation of financial statements in accordance with generally accepted accounting principles, and that receipts and expenditures of the company are being made only in accordance with authorizations of management and directors of the company; and (iii) provide reasonable assurance regarding prevention or timely detection of unauthorized acquisition, use, or disposition of the company's assets that could have a material effect on the financial statements.

Because of its inherent limitations, internal control over financial reporting may not prevent or detect misstatements. Also, projections of any evaluation of effectiveness to future periods are subject to the risk that controls may become inadequate because of changes in conditions, or that the degree of compliance with the policies or procedures may deteriorate.

/s/ PricewaterhouseCoopers LLP
Indianapolis, Indiana
February 20, 2015

Allison Transmission Holdings, Inc.
Consolidated Balance Sheets
(dollars in millions, except share data)

	December 31, 2014	December 31, 2013
ASSETS		
Current Assets		
Cash and cash equivalents	\$ 263.0	\$ 184.7
Accounts receivable — net of allowance for doubtful accounts of \$0.3 and \$0.4, respectively	207.4	175.1
Inventories	143.5	160.4
Deferred income taxes, net	119.7	58.1
Other current assets	24.4	28.6
Total Current Assets	<u>758.0</u>	<u>606.9</u>
Property, plant and equipment, net	514.6	563.4
Intangible assets, net	1,512.0	1,610.8
Goodwill	1,941.0	1,941.0
Deferred income taxes, net	1.3	1.1
Other non-current assets	77.3	89.4
TOTAL ASSETS	<u>\$ 4,804.2</u>	<u>\$ 4,812.6</u>
LIABILITIES		
Current Liabilities		
Accounts payable	\$ 151.7	\$ 150.4
Product warranty liability	24.0	37.4
Current portion of long-term debt	17.9	17.9
Deferred revenue	20.6	29.2
Other current liabilities	131.7	152.3
Total Current Liabilities	<u>345.9</u>	<u>387.2</u>
Product warranty liability	59.6	53.1
Deferred revenue	48.7	43.2
Long-term debt	2,502.6	2,660.4
Deferred income taxes	238.2	76.2
Other non-current liabilities	211.4	153.7
TOTAL LIABILITIES	<u>3,406.4</u>	<u>3,373.8</u>
Commitments and contingencies (see NOTE 17)		
STOCKHOLDERS' EQUITY		
Common stock, \$0.01 par value, 1,880,000,000 shares authorized, 179,488,247 shares issued and outstanding and 183,375,436 shares issued and outstanding, respectively	1.8	1.8
Non-voting common stock, \$0.01 par value, 20,000,000 shares authorized, none issued and outstanding and 1,185 issued and outstanding, respectively	—	0.0
Preferred stock, \$0.01 par value, 100,000,000 shares authorized, none issued and outstanding	—	—
Paid in capital	1,651.0	1,631.8
Accumulated deficit	(215.5)	(173.8)
Accumulated other comprehensive loss, net of tax	(39.5)	(21.0)
TOTAL STOCKHOLDERS' EQUITY	<u>1,397.8</u>	<u>1,438.8</u>
TOTAL LIABILITIES & STOCKHOLDERS' EQUITY	<u>\$ 4,804.2</u>	<u>\$ 4,812.6</u>

The accompanying notes are an integral part of the consolidated financial statements.

Allison Transmission Holdings, Inc.
Consolidated Statements of Comprehensive Income
(dollars in millions, except per share data)

	Years ended December 31,		
	2014	2013	2012
Net sales	\$2,127.4	\$1,926.8	\$2,141.8
Cost of sales	1,151.5	1,084.9	1,187.5
Gross profit	975.9	841.9	954.3
Selling, general and administrative expenses	344.6	334.9	419.0
Engineering — research and development	103.8	97.1	115.1
Loss associated with impairment of long-lived assets	15.4	—	—
Operating income	512.1	409.9	420.2
Interest income	0.9	0.8	0.9
Interest expense	(139.3)	(133.7)	(152.1)
Other expense, net	(5.6)	(10.9)	(52.8)
Income before income taxes	368.1	266.1	216.2
Income tax (expense) benefit	(139.5)	(100.7)	298.0
Net income	\$ 228.6	\$ 165.4	\$ 514.2
Basic earnings per share attributable to common stockholders	\$ 1.27	\$ 0.90	\$ 2.83
Diluted earnings per share attributable to common stockholders	\$ 1.25	\$ 0.88	\$ 2.76
Dividends declared per common share	\$ 0.51	\$ 0.42	\$ 0.18
Other comprehensive (loss) income, net of tax:			
Foreign currency translation	(7.4)	(5.0)	(0.7)
Pension and OPEB liability adjustment	(9.1)	29.0	15.1
Available-for-sale securities	(2.0)	(1.1)	(1.3)
Total other comprehensive (loss) income, net of tax	(18.5)	22.9	13.1
Comprehensive income	\$ 210.1	\$ 188.3	\$ 527.3

The accompanying notes are an integral part of the consolidated financial statements.

Allison Transmission Holdings, Inc.
Consolidated Statements of Cash Flows
(dollars in millions)

	Years ended December 31,		
	2014	2013	2012
CASH FLOWS FROM OPERATING ACTIVITIES:			
Net income	\$ 228.6	\$ 165.4	\$ 514.2
Adjustments to reconcile net income to net cash provided by operating activities:			
Amortization of intangible assets	98.8	105.3	150.0
Depreciation of property, plant and equipment	93.8	98.7	102.5
Deferred income taxes	131.8	98.0	(303.8)
Excess tax benefit from stock-based compensation	(24.6)	(13.7)	(5.3)
Loss associated with impairment of long-lived assets	15.4	—	—
Stock-based compensation	14.7	13.7	6.4
Amortization of deferred financing costs	8.1	10.9	14.5
Unrealized gain on derivatives	(4.7)	(32.8)	(26.2)
Impairment loss on investments in technology-related initiatives	2.0	5.0	14.4
Loss on repayments and repurchases of long-term debt	0.5	0.8	22.1
Other	5.2	2.1	2.1
Changes in assets and liabilities:			
Accounts receivable	(35.8)	(9.9)	29.9
Inventories	12.7	(4.4)	(1.8)
Accounts payable	2.1	17.6	(29.4)
Other assets and liabilities	8.3	(3.2)	7.9
Net cash provided by operating activities	556.9	453.5	497.5
CASH FLOWS FROM INVESTING ACTIVITIES:			
Additions of long-lived assets	(64.1)	(74.4)	(123.9)
Investments in technology-related initiatives	(5.8)	(8.8)	(14.4)
Collateral for interest rate derivatives	1.7	1.2	(1.0)
Proceeds from disposal of assets	0.3	0.5	0.6
Net cash used for investing activities	(67.9)	(81.5)	(138.7)
CASH FLOWS FROM FINANCING ACTIVITIES:			
Repurchase of common stock	(249.8)	(99.5)	—
Payments on long-term debt	(157.6)	(142.4)	(245.4)
Dividend payments	(91.6)	(77.1)	(32.8)
Proceeds from exercise of stock options	59.6	46.3	29.0
Excess tax benefit from stock-based compensation	24.6	13.7	5.3
Taxes paid related to net share settlement of equity awards	(8.4)	(3.6)	—
Debt financing costs	(0.9)	(14.9)	(20.2)
Repurchases of long-term debt	—	—	(326.9)
Payments on notes payable	—	—	(2.5)
Net cash used for financing activities	(424.1)	(277.5)	(593.5)
Effect of exchange rate changes on cash	13.4	10.0	0.9
Net increase (decrease) in cash and cash equivalents	78.3	104.5	(233.8)
Cash and cash equivalents at beginning of period	184.7	80.2	314.0
Cash and cash equivalents at end of period	<u>\$ 263.0</u>	<u>\$ 184.7</u>	<u>\$ 80.2</u>
Supplemental disclosures:			
Interest paid	\$ 140.0	\$ 159.2	\$ 167.3
Income taxes paid	\$ 5.0	\$ 3.8	\$ 10.7

The accompanying notes are an integral part of the consolidated financial statements.

Allison Transmission Holdings, Inc.
Consolidated Statements of Stockholders' Equity
(dollars in millions)

	Common Stock	Non- voting Common Stock	Preferred Stock	Treasury Stock	Paid-in Capital	Accumulated Deficit	Accumulated Other Comprehensive Income (Loss), net of tax	Stockholders' Equity
Balance at December 31, 2011	\$ 1.8	\$ 0.0	\$ —	\$ (0.2)	\$1,560.8	\$ (683.7)	\$ (57.0)	\$ 821.7
Stock-based compensation	—	—	—	—	6.4	—	—	6.4
Pension and OPEB liability adjustment	—	—	—	—	—	—	15.1	15.1
Foreign currency translation adjustment	—	—	—	—	—	—	(0.7)	(0.7)
Available-for-sale securities	—	—	—	—	—	—	(1.3)	(1.3)
Issuance of common stock	0.0	—	—	—	29.0	—	—	29.0
Dividends on common stock	—	—	—	—	—	(32.8)	—	(32.8)
Excess tax benefit from stock-based compensation	—	—	—	—	5.3	—	—	5.3
Net income	—	—	—	—	—	514.2	—	514.2
Balance at December 31, 2012	\$ 1.8	\$ 0.0	\$ —	\$ (0.2)	\$1,601.5	\$ (202.3)	\$ (43.9)	\$ 1,356.9
Stock-based compensation	—	—	—	—	13.7	—	—	13.7
Pension and OPEB liability adjustment	—	—	—	—	—	—	29.0	29.0
Foreign currency translation adjustment	—	—	—	—	—	—	(5.0)	(5.0)
Available-for-sale securities	—	—	—	—	—	—	(1.1)	(1.1)
Issuance of common stock	0.0	—	—	—	42.6	—	—	42.6
Repurchase of common stock	(0.0)	—	—	—	(39.7)	(59.8)	—	(99.5)
Retirement of treasury stock	—	—	—	0.2	—	—	—	0.2
Dividends on common stock	—	—	—	—	—	(77.1)	—	(77.1)
Excess tax benefit from stock-based compensation	—	—	—	—	13.7	—	—	13.7
Net income	—	—	—	—	—	165.4	—	165.4
Balance at December 31, 2013	\$ 1.8	\$ 0.0	\$ —	\$ —	\$1,631.8	\$ (173.8)	\$ (21.0)	\$ 1,438.8
Stock-based compensation	—	—	—	—	14.7	—	—	14.7
Pension and OPEB liability adjustment	—	—	—	—	—	—	(9.1)	(9.1)
Foreign currency translation adjustment	—	—	—	—	—	—	(7.4)	(7.4)
Available-for-sale securities	—	—	—	—	—	—	(2.0)	(2.0)
Issuance of common stock	0.0	—	—	—	51.0	—	—	51.0
Repurchase of common stock	(0.0)	(0.0)	—	—	(71.1)	(178.7)	—	(249.8)
Dividends on common stock	—	—	—	—	—	(91.6)	—	(91.6)
Excess tax benefit from stock-based compensation	—	—	—	—	24.6	—	—	24.6
Net income	—	—	—	—	—	228.6	—	228.6
Balance at December 31, 2014	\$ 1.8	\$ —	\$ —	\$ —	\$1,651.0	\$ (215.5)	\$ (39.5)	\$ 1,397.8

The accompanying notes are an integral part of the consolidated financial statements.

Allison Transmission Holdings, Inc.

Notes to Consolidated Financial Statements

NOTE 1. OVERVIEW

Overview

Allison Transmission Holdings, Inc. and its subsidiaries (“Allison,” the “Company” or “we”) design and manufacture commercial and defense fully-automatic transmissions. The business was founded in 1915 and has been headquartered in Indianapolis, Indiana since inception. Allison was an operating unit of General Motors Corporation (“Old GM”) from 1929 until 2007, when Allison once again became a stand-alone company. In March 2012, Allison began trading on the New York Stock Exchange under the symbol, “ALSN”.

We have approximately 2,700 employees and 13 different transmission product lines. Although approximately 80% percent of revenues were generated in North America in 2014, we have a global presence by serving customers in Europe, Asia, South America and Africa. We serve customers through an independent network of approximately 1,400 independent distributor and dealer locations worldwide.

NOTE 2. SUMMARY OF SIGNIFICANT ACCOUNTING POLICIES

Basis of Presentation and Principles of Consolidation

The consolidated financial statements have been prepared in accordance with accounting principles generally accepted in the United States of America (“GAAP”). The information herein reflects all normal recurring material adjustments, which are, in the opinion of management, necessary for the fair statements of the results for the periods presented. The consolidated financial statements herein consist of all wholly-owned domestic and foreign subsidiaries with all significant intercompany transactions eliminated.

These consolidated financial statements present the financial position, results of comprehensive income, cash flows and statements of equity. Certain immaterial reclassifications have been made in the consolidated financial statements of prior periods to conform to the current period presentation. These reclassifications have no impact on previously reported net income, total stockholders’ equity or cash flows.

Use of Estimates

The preparation of financial statements in conformity with GAAP requires management to make estimates and assumptions that affect the reported amounts of assets and liabilities, disclosure of contingent assets and liabilities and the reported amounts of revenue and expenses. Significant estimates include, but are not limited to, allowance for doubtful accounts, sales allowances, government price adjustments, fair market values and future cash flows associated with goodwill, indefinite-life intangibles, long-lived asset impairment tests, useful lives for depreciation and amortization, warranty liability, determination of discount and other assumptions for pension and other postretirement benefit expense, income taxes and deferred tax valuation allowances, derivative valuation, and contingencies. The Company’s accounting policies involve the application of judgments and assumptions made by management that include inherent risks and uncertainties. Actual results could differ materially from these estimates. Changes in estimates are recorded in results of operations in the period that the events or circumstances giving rise to such changes occur.

Segment Reporting

In accordance with the Financial Accounting Standards Board (“FASB”) authoritative accounting guidance on segment reporting, the Company has one operating segment and reportable segment. The Company is in one line of business, which is the manufacture and distribution of fully-automatic transmissions.

Government Grants

The Company recognizes government grants when there is reasonable assurance that the Company will comply with the conditions attached to the grant arrangement and the funds will be received. When the government grants relate to reimbursement of costs, the grant income is recognized in Other expense, net in the Consolidated Statements of Comprehensive Income. When the government grants relate to a reimbursement of capital expenditures, the grants are recognized as a reduction of the basis of the assets in the Consolidated Balance Sheets.

Cash and Cash Equivalents

Cash equivalents are defined as short-term, highly-liquid investments with original maturities of 90 days or less. Under the Company's cash management system, checks issued but not presented to banks may result in book overdraft balances for accounting purposes and are classified within Accounts payable in the Consolidated Balance Sheets. The change in book overdrafts is reported as a component of operating cash flows for Accounts payable.

Marketable Securities

The Company determines the appropriate classification of all marketable securities as "held-to-maturity," "available-for-sale" or "trading" at the time of purchase, and re-evaluates such classifications as of each balance sheet date. As of December 31, 2014, the Company's marketable securities are classified as either available-for-sale or trading.

Available-for-sale securities are carried at fair value with the unrealized gain or loss reported in Accumulated other comprehensive loss ("AOCL"). Unrealized gains or losses considered to be "other-than-temporary" are recognized in income. Trading securities are carried at fair value with the unrealized gain or loss recognized in Other expense, net. The fair value of the Company's investment securities is determined by currently available market prices. See NOTE 6 for more details.

Allowance for Doubtful Accounts

The allowance for doubtful trade accounts receivable reflects estimated losses to be incurred in the collection of the receivables. Estimated losses are based on historical collection experience as well as a review by management of the current status of all receivables. Account balances are charged against the allowance after all means of collection have been exhausted and the potential for recovery is considered remote.

Inventories

Inventories are stated at the lower of cost or market. The Company determines cost using the first-in, first-out method. The Company analyzes inventory on a quarterly basis to determine whether it is excess or obsolete inventory. Any decline in carrying value of estimated excess or obsolete inventory is recorded as a reduction of inventory and as an expense included in Cost of sales in the period it is identified.

Property, Plant and Equipment

Property, plant and equipment are recorded at cost less accumulated depreciation. Depreciation expense is recorded using the straight-line method over the following estimated lives:

	Range in Years
Land improvements	5 – 30
Buildings and building improvements	10 – 40
Machinery and equipment	2 – 20
Software	2 – 5
Special tools	2 – 10

Software represents the costs of software developed or obtained for internal use. Software costs are amortized on a straight-line basis over their estimated useful lives. Software assets are reviewed for impairment when events or circumstances indicate that the carrying value may not be recoverable over the remaining lives of the assets. Upgrades and enhancements are capitalized if they result in added functionality, which enables the software to perform tasks it was previously incapable of performing. Software maintenance, training, data conversion and business process reengineering costs are expensed in the period in which they are incurred.

Special tooling represents the costs to design and develop tools, dies, jigs and other items owned by the Company and used in the manufacture of components by suppliers under long-term supply agreements. Special tooling is depreciated over the tool's expected life. Special tooling used in the development of new technology is expensed as incurred. Engineering, testing and other costs incurred in the design and development of production parts are expensed as incurred.

Impairment of Long-Lived Assets

The carrying value of long-lived assets is evaluated whenever events or circumstances indicate that the carrying value of an asset may not be recoverable. Events or circumstances that would result in an impairment review primarily include a significant change in the use of an asset, or the planned sale or disposal of an asset. The asset would be considered impaired when there is no future use planned for the asset or the future net undiscounted cash flows generated by the asset or asset group are less than its carrying value. An impairment loss would be recognized based on the amount by which the carrying value exceeds fair value.

Assumptions and estimates used to determine cash flows in the evaluation of impairment and the fair values used to determine the impairment are subject to a degree of judgment and complexity. Any changes to the assumptions and estimates resulting from changes in actual results or market conditions from those anticipated may affect the carrying value of long-lived assets and could result in an impairment charge.

As a result of events and circumstances in the fourth quarter of 2014, the Company reviewed certain of its long-lived assets related to the production of the H3000 and H4000 hybrid-propulsion systems, resulting in a \$15.4 million loss recorded for the year ended December 31, 2014. The loss, determined by using future net discounted cash flows, included approximately \$1.7 million of accrued expenses related to the impairment of the long-lived assets. Deteriorating market conditions for hybrid-propulsion vehicles, principally as a result of decreased fuel costs, alternative fuels and other technologies, significantly contributed to the future cash flows of the related assets being less than the carrying value of those assets.

Goodwill and Other Intangible Assets

Goodwill represents the excess of purchase price paid over the fair value of net assets acquired. In accordance with the FASB's authoritative accounting guidance on goodwill, the Company does not amortize goodwill but rather evaluates it for impairment on an annual basis, or more often if events or circumstances change that could cause goodwill to become impaired. Goodwill is tested for impairment at the reporting unit level, which is the same as the Company's one operating and reportable segment. The Company has elected to perform its annual impairment test on October 31 of every year. A multi-step impairment test is performed on goodwill. In Step 0, the Company has the option to evaluate various qualitative factors to determine the likelihood of impairment. If determined that the fair value is more likely than not less than the carrying value, then the Company is required to perform Step 1. If the Company does not elect to perform Step 0, it can voluntarily proceed directly to Step 1. In Step 1, the Company performs a quantitative analysis to compare the fair value of its reporting unit to its carrying value including goodwill. If the fair value of the reporting unit exceeds the carrying value of the net assets assigned to that unit, goodwill is not considered impaired, and the Company is not required to perform further testing. If the carrying value of the net assets assigned to the reporting unit exceeds the fair value of the reporting unit, then the Company must perform Step 2 of the impairment test in order to determine the implied fair value of the reporting unit's goodwill. If the carrying value of a reporting unit's goodwill exceeds its implied fair value, then the Company would record an impairment loss equal to the difference.

Goodwill impairment testing for 2014 was performed by assessing certain qualitative trends and factors. The Company's qualitative assessment included an assessment of business changes, economic outlook, financial trends and forecasts, growth rates, credit ratings, equity ratings, discount rates, industry data and other relevant qualitative factors. Events or circumstances that could unfavorably impact the key assumptions include lower net sales driven by market conditions, our inability to execute on marketing programs and/or delay in the introduction of new products, lower gross margins as a result of market conditions or failure to obtain forecasted cost reductions, or a higher discount rate as a result of market conditions. While unpredictable and inherently uncertain, the Company believes its forecast estimates are reasonable and incorporate assumptions that similar market participants would use in their estimates of fair value. These trends and factors were compared to, and based on, the assumptions used in the quantitative assessment performed in 2013. After reviewing various qualitative factors, the Company's 2014 annual goodwill impairment test indicated that the fair value of the reporting unit more likely than not exceeded its carrying value, indicating no impairment.

Other intangible assets have both indefinite and finite useful lives. Intangible assets with indefinite useful lives, such as the Company's trade name, are not amortized but are tested annually for impairment. The Company has elected to perform our annual trade name impairment test on October 31 of every year and follow a similar multi-step impairment test that is performed on goodwill. After reviewing various qualitative factors, the Company's 2014 annual trade name impairment test indicated that the fair value of the trade name more likely than not exceeded its carrying value, indicating no impairment. The qualitative review included an assessment of various key assumptions and factors including, among others, an assessment of business changes, economic outlooks, financial trends and forecasts, royalty savings rates, credit ratings, equity ratings and discount rates. Events or circumstances that could unfavorably impact the key assumptions include lower net sales driven by market conditions, our inability to execute on marketing programs and/or delay in introduction of new products, and higher discount rate as a result of market conditions. While unpredictable and inherently uncertain, we believe the forecast estimates are reasonable and incorporate those assumptions that similar market participants would use in their estimates of fair value. These trends and factors were compared to, and based on, the assumptions used in the quantitative assessment performed in 2013. After reviewing various qualitative factors, the fair value of trade name exceeded the respective carrying value.

[Table of Contents](#)

Intangible assets with finite lives are amortized over their estimated useful lives and reviewed for impairment when circumstances change that would create a triggering event. Customer relationships are amortized over the life in which expected benefits are to be consumed. The other remaining finite useful life intangibles are amortized on a straight-line basis over their useful lives. The Company evaluates the remaining useful life of the other intangible assets on a periodic basis to determine whether events or circumstances warrant a revision to the remaining useful life. Assumptions and estimates about future values and remaining useful lives of the Company's intangible and other long-lived assets are complex and subjective. They can be affected by a variety of factors, including external factors such as industry and economic trends, and internal factors, such as changes in the Company's business strategy and internal forecasts. Although management believes the historical assumptions and estimates are reasonable and appropriate, different assumptions and estimates could materially impact the Company's reported financial results.

NOTE 5 provides further information on Goodwill and Other intangible assets.

Deferred Financing Costs

Deferred financing costs are stated at cost as a component of other non-current assets and amortized over the life of the related debt using the effective interest method. Amortization of deferred financing costs is recorded as part of interest expense and totaled \$8.1 million, \$10.9 million and \$14.5 million for the years ended December 31, 2014, 2013 and 2012, respectively.

Financial Instruments

The Company's cash equivalents are invested in U.S. Government backed securities and recorded at fair value in the Consolidated Balance Sheets. The carrying values of accounts receivable and accounts payable approximate fair value due to their short-term nature. The Company's financial derivative instruments, including interest rate swaps and foreign currency and commodity forward contracts are carried at fair value on the Consolidated Balance Sheets. Refer to NOTE 6 for more detail. The Company's long-term debt obligations are carried at historical amounts with the Company providing fair value disclosure in NOTE 7.

Insurable Liabilities

The Company records liabilities for its medical, workers' compensation, long-term disability, product, general and auto liabilities. The determination of these liabilities and related expenses is dependent on claims experience. For most of these liabilities, claims incurred but not yet reported are estimated based upon historical claims experience.

Revenue Recognition

The Company records sales when title has transferred to the customer, there is evidence of an agreement, the sales price is fixed or determinable, delivery has occurred or services have been rendered, and collectability is reasonably assured. The Company sells Extended Transmission Coverage ("ETC") for which sales are deferred. ETC sales are recognized ratably over the period of the ETC, which typically ranges from two to five years after initial sale. Costs associated with ETC programs are recorded as incurred during the extended period. Distributor and customer sales incentives, consisting of allowances and other rebates, are estimated at the time of sale based upon the Company's history and experience and are recorded as a reduction to Net sales. Incentive programs are generally product specific or region specific. Some factors used in estimating the cost of incentives include the number of transmissions that will be affected by the incentive program and rate of acceptance of any incentive program. If the actual number of affected transmissions differs from this estimate, or if a different mix of incentives is actually paid, the impact on Net sales would be recorded in the period that the change was identified. Consideration given to commercial customers recorded as a reduction of Net sales in the Consolidated Statements of Comprehensive Income included \$66.9 million, \$65.2 million, and \$59.9 million for the years ended December 31, 2014, 2013 and 2012, respectively.

Sales under U.S. government production contracts are recorded when the product is accepted, title has transferred to the U.S. government, the sales price is fixed or determinable, and delivery has occurred. Deferred revenue arises from cash received in advance of the culmination of the earnings process and is recognized as revenue in future periods when the applicable revenue recognition criteria have been met. Under the terms of the U.S. government contracts, there are certain price reduction clauses and provisions for potential price reductions which are estimated at the time of sale based upon the Company's history and experience and are recorded as a reduction to Net sales. Potential reductions may be attributed to a change in projected sales volumes or plant efficiencies which impact overall costs. As of December 31, 2014 and 2013, the Company had \$63.1 million and \$49.6 million recorded in the price reduction reserve account, respectively.

Due to requests from the U.S. government, the Company billed, but did not ship certain tracked transmissions during 2013. Based on the lack of a fixed delivery date from the U.S. government, the Company deferred approximately \$8.8 million of net sales for these transmissions until they were shipped in 2014. See NOTE 10 for additional details.

[Table of Contents](#)

The Company classifies shipping and handling billed to customers in Net sales and shipping and handling costs in Cost of sales, in accordance with authoritative accounting guidance.

The Company contracts with various third parties to provide engineering services. These services are recorded as Net sales in accordance with the terms of the contract. The saleable engineering recorded was \$7.4 million, 12.4 million and \$7.8 million for the years ended December 31, 2014, 2013 and 2012, respectively. The associated costs are recorded in Cost of sales.

Warranty

Provisions for estimated expenses related to product warranties are made at the time products are sold. Warranty claims arise when a transmission fails while in service during the relevant warranty period. The warranty reserve is adjusted in Selling, general and administrative expenses based on the Company's current and historical warranty claims paid and associated repair costs. These estimates are established using historical information including the nature, frequency, and average cost of warranty claims and are adjusted as actual information becomes available. From time to time, the Company may initiate a specific field action program. As a result of the uncertainty surrounding the nature and frequency of specific field action programs, the liability for such programs is recorded when the Company commits to an action. The Company reviews and assesses the liability for these programs on a quarterly basis. The Company also assesses its ability to recover certain costs from its suppliers and records a receivable from the supplier when it believes a recovery is probable.

Research and Development

The Company incurs costs in connection with research and development programs that are expected to contribute to future earnings. Such costs are charged to Engineering — research and development as incurred.

Foreign Currency Translation

Most of the subsidiaries outside the United States prepare financial statements in currencies other than the U.S. dollar. The functional currency for all these subsidiaries is the local currency, except for the Company's Hong Kong and Middle East subsidiaries which currently use the U.S. dollar as their functional currency. Balances are translated at period-end exchange rates for assets and liabilities and monthly weighted-average exchange rates for revenues and expenses. The translation gains (losses) are stated as a component of AOCL as disclosed in NOTE 16.

Derivative Instruments

In the normal course of business, the Company is exposed to fluctuations in interest rates, foreign currency exchange rates, and commodity prices. The risk is managed through the use of financial derivative instruments including interest rate swaps and commodity and foreign currency forward contracts. Despite the fact that the Company either has not elected or does not qualify for hedge accounting treatment on all of its derivative instruments, the contracts are used strictly as an economic hedge and not for speculative purposes. As necessary, the Company adjusts the values of the derivative instruments for counter-party or credit risk. NOTE 8 provides further information on the accounting treatment of the Company's derivative instruments.

Income Taxes

Income taxes are accounted for under the asset and liability method. Deferred tax assets and liabilities are recognized for the expected future tax consequences attributable to temporary differences between the financial statement carrying amounts of existing assets and liabilities and their respective tax bases. The future tax benefits associated with operating loss and tax credit carryforwards are recognized as deferred tax assets. Deferred tax assets and liabilities are measured using enacted tax rates expected to apply to taxable income in the years in which those temporary differences are expected to be recovered or settled.

The need to establish a valuation allowance against the deferred tax assets is assessed periodically based on a more-likely-than-not realization threshold, in accordance with the FASB's authoritative accounting guidance on income taxes. Appropriate consideration is given to all positive and negative evidence related to that realization. This assessment considers, among other matters, the nature, frequency and severity of recent losses, forecasts of future profitability, the duration of statutory carryforward periods, and experience with tax attributes expiring unused and tax planning alternatives. The weight given to these considerations depends upon the degree to which they can be objectively verified.

Stock-Based Compensation

The Company maintains a stock-based compensation plan which allows employees (including executive officers), consultants and directors to receive equity awards. The Company has adopted the FASB's authoritative accounting guidance on share-based payments and recognizes the fair value of the awards as compensation expense over the vesting period. The accounting guidance also requires that forfeitures be estimated over the vesting period of an award instead of being recognized as a reduction of compensation expense when the forfeiture actually occurs.

Pension and Post-retirement Benefit Plans

For pension and other post-retirement benefits (“OPEB”) plans in which employees participate, costs are determined within the FASB’s authoritative accounting guidance set forth in employers’ defined benefit pensions including accounting for settlements and curtailments of defined benefit pension plans, termination of benefits and accounting for post-retirement benefits other than pensions. In accordance with the authoritative accounting guidance, the Company recognizes the funded status of its defined benefit pension plans and OPEB plan in its Consolidated Balance Sheets with a corresponding adjustment to AOCL, net of tax.

Post-retirement benefit costs consist of service cost, interest cost on accrued obligations and the expected return on assets (calculated using a smoothed market value of assets). Any difference between actual and expected returns on assets during a year and actuarial gains and losses on liabilities together with any prior service costs are charged (or credited) to income over the average remaining service lives of employees.

The benefit cost components shown in the Consolidated Statements of Comprehensive Income are based upon various actuarial assumptions and methodologies as prescribed by authoritative accounting guidance. These assumptions include discount rates, expected return on plan assets, health care cost trend rates, inflation, rate of compensation increases, population demographics, mortality rates and other factors. The Company reviews all actuarial assumptions on an annual basis. Changes in key economic indicators can change these assumptions. These assumptions, along with the actual value of assets at the measurement date, will impact the calculation of pension expenses for the year. For instance, the effect of a one percentage point decrease in the assumed discount rate would result in an increase in the December 31, 2014 defined benefit pension plans obligation of approximately \$20.0 million. Similarly, a one percentage point decrease in the assumed discount rate would result in an increase in the December 31, 2014 OPEB obligation of approximately \$23.7 million.

Recently Issued Accounting Pronouncements

In August 2014, the FASB issued authoritative accounting guidance on the disclosure of uncertainties about an entity’s ability to continue as a going concern. The guidance requires management to evaluate whether there is substantial doubt about an entity’s ability to continue as a going concern within one year after the date that the financial statements are issued (or within one year after the date that financial statements are available to be issued when applicable) and to provide related footnote disclosures. The guidance is effective prospectively for fiscal years beginning after December 15, 2016, but can be early-adopted. While the adoption of this guidance is not expected to have an effect on the Company’s consolidated financial statements, it could affect the disclosure applied under these circumstances in the future.

In May 2014, the FASB issued authoritative accounting guidance on a company’s accounting for revenue from contracts with customers. The guidance applies to all companies that enter into contracts with customers to transfer goods, service or nonfinancial assets. The guidance requires these companies to recognize revenue to depict the transfer of promised goods or services to customers in an amount that reflects the consideration to which the entity expects to be entitled in exchange for those goods or services. The guidance also requires improved disclosures regarding the nature, timing, amount and uncertainty of revenue that is recognized. The guidance is effective prospectively for fiscal years beginning after December 15, 2016. Management is currently assessing the potential impact of the adoption of this guidance on the Company’s consolidated financial statements.

NOTE 3. INVENTORIES

Inventories consisted of the following components (dollars in millions):

	<u>December 31,</u> <u>2014</u>	<u>December 31,</u> <u>2013</u>
Purchased parts and raw materials	\$ 72.3	\$ 79.7
Work in progress	6.1	5.7
Service parts	46.5	45.8
Finished goods	18.6	29.2
Total inventories	<u>\$ 143.5</u>	<u>\$ 160.4</u>

Inventory components shipped to third parties, primarily cores, parts to re-manufacturers, and parts to contract manufacturers, in which the Company has an obligation to buy back, are included in purchased parts and raw materials, with an offsetting liability in Other current liabilities. See NOTE 12, "Other Current Liabilities" for more information.

NOTE 4. PROPERTY, PLANT AND EQUIPMENT

The cost and accumulated depreciation of property, plant and equipment are as follows (dollars in millions):

	<u>December 31,</u> <u>2014</u>	<u>December 31,</u> <u>2013</u>
Land and land improvements	\$ 23.6	\$ 20.3
Buildings and building improvements	281.6	271.4
Machinery and equipment	576.2	567.7
Software	117.0	112.9
Special tools	143.6	143.4
Construction in progress	39.9	48.6
Total property, plant and equipment	<u>1,181.9</u>	<u>1,164.3</u>
Accumulated depreciation	<u>(667.3)</u>	<u>(600.9)</u>
Property, plant and equipment, net	<u>\$ 514.6</u>	<u>\$ 563.4</u>

Depreciation of property, plant and equipment was \$93.8 million, \$98.7 million and \$102.5 million for the years ended December 31, 2014, 2013 and 2012, respectively.

During 2014, the Company recorded an impairment of certain machinery and equipment, and special tools associated with the production of the H3000 and H4000 hybrid-propulsion systems. See NOTE 2, "Impairment of long-lived assets" for more information.

NOTE 5. GOODWILL AND OTHER INTANGIBLE ASSETS

As of December 31, 2014 and 2013, the carrying amount of the Company's Goodwill was \$1,941.0 million.

The following presents a summary of other intangible assets (dollars in millions):

	December 31, 2014			December 31, 2013		
	Intangible assets, gross	Accumulated amortization	Intangible assets, net	Intangible assets, gross	Accumulated amortization	Intangible assets, net
Other intangible assets:						
Trade name	\$ 870.0	\$ —	\$ 870.0	\$ 870.0	\$ —	\$ 870.0
Customer relationships - defense	62.3	(27.9)	34.4	62.3	(24.4)	37.9
Customer relationships - commercial	831.8	(426.9)	404.9	831.8	(374.9)	456.9
Proprietary technology	476.3	(282.0)	194.3	476.3	(243.9)	232.4
Non-compete agreement	17.3	(12.8)	4.5	17.3	(11.1)	6.2
Patented technology - defense	28.2	(24.5)	3.7	28.2	(21.2)	7.0
Tooling rights	4.5	(4.3)	0.2	4.5	(4.1)	0.4
Patented technology - commercial	260.6	(260.6)	—	260.6	(260.6)	—
Total	<u>\$ 2,551.0</u>	<u>\$ (1,039.0)</u>	<u>\$ 1,512.0</u>	<u>\$ 2,551.0</u>	<u>\$ (940.2)</u>	<u>\$ 1,610.8</u>

Amortization of intangible assets was \$98.8 million, \$105.3 million and \$150.0 million for the years ended December 31, 2014, 2013 and 2012, respectively.

As of December 31, 2014, the net carrying value of the Company's Goodwill and Other intangible assets, net was \$3,453.0 million.

Amortization expense related to other intangible assets for the next five years and thereafter is expected to be (dollars in millions):

	2015	2016	2017	2018	2019	Thereafter
Amortization expense	<u>\$97.1</u>	<u>\$92.4</u>	<u>\$89.7</u>	<u>\$87.2</u>	<u>\$85.7</u>	<u>\$ 189.9</u>

NOTE 6. FAIR VALUE OF FINANCIAL INSTRUMENTS

In accordance with the FASB's authoritative accounting guidance on fair value measurements, fair value is the price that would be received to sell an asset or paid to transfer a liability in an orderly transaction between market participants at the measurement date. The Company utilizes market data or assumptions that market participants would use in pricing the asset or liability, including assumptions about risk and the risks inherent in the inputs to the valuation technique. These inputs can be readily observable, market corroborated, or generally unobservable. The Company primarily applies the market approach for recurring fair value measurements and utilizes the best available information that maximizes the use of observable inputs and minimizes the use of unobservable inputs. The Company is able to classify fair value balances based on the observability of those inputs. The accounting guidance establishes a fair value hierarchy that prioritizes the inputs used to measure fair value. The hierarchy gives the highest priority to unadjusted quoted prices in active markets for identical assets or liabilities (Level 1 measurement) and the lowest priority to unobservable inputs (Level 3 measurement). The three levels of the fair value hierarchy defined by the relevant guidance are as follows:

Level 1 — Quoted prices are available in active markets for identical assets or liabilities as of the reporting date. Active markets are those in which transactions for the asset or liability occur in sufficient frequency and volume to provide pricing information on an ongoing basis. Level 1 primarily consists of financial instruments such as exchange-traded derivatives, listed equities and publicly traded bonds.

Level 2 — Pricing inputs are other than quoted prices in active markets included in Level 1, which are either directly or indirectly observable as of the reported date. Level 2 includes financial instruments that are valued using quoted prices in markets that are not active and those financial instruments that are valued using models or other valuation methodologies. These models are primarily industry standard models that consider various assumptions, including quoted forward prices for commodities, time value, volatility factors, and current market and contractual prices for the underlying instruments, as well as other relevant economic measures. Substantially all of these assumptions are observable in the marketplace throughout the full term of the instrument, can be derived from observable data or are supported by observable levels at which transactions are executed in the marketplace.

Level 3 — Pricing inputs include significant inputs that are generally less observable from objective sources. These inputs may be used with internally developed methodologies that result in management's best estimate of fair value. At each balance sheet date, the Company performs an analysis of all instruments subject to authoritative accounting guidance and includes, in Level 3, all of those whose fair value is based on significant unobservable inputs. As of December 31, 2014 and 2013, the Company did not have any Level 3 financial assets or liabilities.

The Company's assets and liabilities that are measured at fair value include cash and cash equivalents, available-for-sale securities, derivative instruments, assets held in a rabbi trust and a deferred compensation obligation. The Company's cash equivalents consist of short-term U.S. government backed securities. The Company's available-for-sale securities consist of ordinary shares of Torotrak plc ("Torotrak") associated with a license and exclusivity agreement with Torotrak. Torotrak's listed shares are traded on the London Stock Exchange under the ticker symbol "TRK." The Company's derivative instruments consist of interest rate swaps, foreign currency forward contracts and commodity swaps. The Company's assets held in the rabbi trust consist principally of publicly available mutual funds and target date retirement funds. The Company's deferred compensation obligation is directly related to the fair value of assets held in the rabbi trust.

The Company's valuation techniques used to calculate the fair value of cash and cash equivalents, available-for-sale securities, assets held in the rabbi trust and the deferred compensation obligation represent a market approach in active markets for identical assets that qualify as Level 1 in the fair value hierarchy. The Company's valuation techniques used to calculate the fair value of derivative instruments represent a market approach with observable inputs that qualify as Level 2 in the fair value hierarchy.

The foreign currency contracts consist of forward rate contracts which are intended to hedge exposure of transactions denominated in certain currencies and reduce the impact of currency price volatility on the Company's financial results. The commodity contracts consist of forward rate contracts which are intended to hedge exposure of transactions involving purchases of component parts and energy to power our facilities, reducing the impact of commodity price volatility on the Company's financial results.

For the fair value measurement of foreign currency derivatives, the Company uses forward foreign exchange rates received from the issuing financial institution. These rates are periodically corroborated by comparing to third-party broker quotes. The foreign currency hedges are accounted for within the authoritative accounting guidance set forth on accounting for derivative instruments and hedging activities and have been recorded at fair value based upon quoted market rates. The fair values are included in Other current and non-current assets and liabilities in the Consolidated Balance Sheets. The Company generally does not elect to apply hedge accounting for these foreign currency contracts, and as a result, unrealized fair value adjustments and realized gains and losses are recorded in Other expense, net in the Consolidated Statements of Comprehensive Income during the period of change.

[Table of Contents](#)

For the fair value measurement of commodity derivatives, the Company uses forward prices received from the issuing financial institution. These rates are periodically corroborated by comparing to third-party broker quotes. The commodity derivatives are accounted for within the authoritative accounting guidance set forth on accounting for derivative instruments and hedging activities and have been recorded at fair value based upon quoted market rates. The fair values are included in Other current and non-current assets and liabilities in the Consolidated Balance Sheets. The Company has either not qualified for or not elected hedge accounting treatment for these commodity contracts, and as a result, unrealized fair value adjustments and realized gains and losses are recorded in Other expense, net in the Consolidated Statements of Comprehensive Income.

For the fair value measurement of interest rate derivatives, the Company uses valuations from the issuing financial institution. The Company corroborates the valuation through the use of third-party valuation services using a standard replacement valuation model. The floating-to-fixed interest rate swaps are based on the London Interbank Offered Rate (“LIBOR”) which is observable at commonly quoted intervals. The fair values are included in other current and non-current assets and liabilities in the Consolidated Balance Sheets. The Company has not qualified for hedge accounting treatment for the interest rate swaps and, as a result, fair value adjustments are charged directly to Interest expense in the Consolidated Statements of Comprehensive Income.

The following table summarizes the fair value of the Company’s financial assets and (liabilities) as of December 31 (dollars in millions):

	Fair Value Measurements Using					
	Quoted Prices in Active Markets for Identical Assets (Level 1)		Significant Other Observable Inputs (Level 2)		TOTAL	
	2014	2013	2014	2013	2014	2013
Cash equivalents	\$ 55.0	\$ 5.0	\$ —	\$ —	\$ 55.0	\$ 5.0
Available-for-sale securities	8.6	8.2	—	—	8.6	8.2
Rabbi trust assets	2.9	1.3	—	—	2.9	1.3
Deferred compensation obligation	(2.9)	(1.3)	—	—	(2.9)	(1.3)
Derivative assets	—	—	0.0	1.6	0.0	1.6
Derivative liabilities	—	—	(15.4)	(21.4)	(15.4)	(21.4)
Total	\$ 63.6	\$ 13.2	\$ (15.4)	\$ (19.8)	\$ 48.2	\$ (6.6)

NOTE 7. DEBT

Long-term debt and maturities are as follows (dollars in millions):

	December 31, 2014	December 31, 2013
Long-term debt:		
Senior Secured Credit Facility Term B-2 Loan, variable, due 2017	\$ 283.6	\$ 423.5
Senior Secured Credit Facility Term B-3 Loan, variable, due 2019	1,765.6	1,783.5
Senior Notes, fixed 7.125%, due 2019	471.3	471.3
Total long-term debt	\$ 2,520.5	\$ 2,678.3
Less: current maturities of long-term debt	17.9	17.9
Total long-term debt less current portion	\$ 2,502.6	\$ 2,660.4

Principal payments required on long-term debt during the next five years are as follows:

(dollars in millions) Payment	Required Principal Payments				
	2015	2016	2017	2018	2019
	\$17.9	\$17.9	\$301.4	\$17.9	\$2,165.4

As of December 31, 2014, the Company had \$283.6 million of indebtedness associated with Allison Transmission, Inc.'s ("ATI"), the Company's wholly-owned subsidiary, Senior Secured Credit Facility Term B-2 Loan due 2017 ("Term B-2 Loan") and \$1,765.6 million of indebtedness associated with ATI's Senior Secured Credit Facility Term B-3 Loan due 2019 ("Term B-3 Loan" and together with the Term B-2 Loan and revolving credit facility, the "Senior Secured Credit Facility"). The Company also had indebtedness of \$471.3 million of ATI's 7.125% senior cash pay notes due May 2019 ("7.125% Senior Notes").

The fair value of the Company's long-term debt obligations as of December 31, 2014 was \$2,515.9 million. The fair value is based on quoted Level 2 market prices of the Company's debt as of December 31, 2014. It is not expected that the Company would be able to repurchase a significant amount of its debt at these levels. The difference between the fair value and carrying value of the long-term debt is driven primarily by trends in the financial markets.

Senior Secured Credit Facility

In March 2012, ATI entered into an amendment with the term loan lenders under its Senior Secured Credit Facility to extend the maturity of \$801.1 million in principal amount of term loan debt from August 2014 to August 2017 and to increase the applicable margin at the Company's option to either (a) 3.50% over the LIBOR or (b) 2.50% over the greater of the prime lending rate provided by the British Banking Association or the federal funds effective rate published by the Federal Reserve Bank of New York plus 0.50%. As a result of the debt modification, the Company recorded an additional \$2.3 million as deferred financing fees in the Consolidated Balance Sheets and extended the amortization period of \$5.1 million of deferred financing fees from 2014 to 2017.

In August 2012, ATI entered into an amendment with the term loan lenders under its Senior Secured Credit Facility to extend the maturity of \$850.0 million of term loan debt from August 2014 to August 2019 and to increase the applicable margin at the Company's option to either (a) 3.25% or 3.00%, subject to the Company's total leverage ratio, over the LIBOR (which may not be less than 1.00%) or (b) 2.25% or 2.00%, subject to the Company's total leverage ratio, over the greater of the prime lending rate provided by the British Banking Association or the federal funds effective rate published by the Federal Reserve Bank of New York plus 0.5% (which may not be less than 2.00%). The amendment was treated as an extinguishment of debt under GAAP, and thus the Company expensed \$4.5 million of deferred financing fees and recorded \$16.1 million of new deferred financing fees in the consolidated financial statements.

In October 2012, ATI entered into an amendment with the term loan lenders under its Senior Secured Credit Facility to extend the maturity of \$300.0 million of term loan debt from August 2014 to August 2019 and to increase the applicable margin at the Company's option to either (a) 3.25% or 3.00%, subject to the Company's total leverage ratio, over the LIBOR (which may not be less than 1.00%) or (b) 2.25% or 2.00%, subject to the Company's total leverage ratio, over the greater of the prime lending rate provided by the British Banking Association or the federal funds effective rate published by the Federal Reserve Bank of New York plus 0.50% (which may not be less than 2.00%). The amendment was treated as an extinguishment of debt under GAAP, and thus the Company expensed \$1.4 million of deferred financing fees and recorded \$1.8 million of new deferred financing fees in the consolidated financial statements.

[Table of Contents](#)

In February 2013, ATI entered into an amendment with the term loan lenders under its Senior Secured Credit Facility to refinance \$793.1 million of term loan debt and decrease the applicable margin for such term loans at the Company's option to either (a) 3.00% over the LIBOR or (b) 2.00% over the greater of the prime lending rate provided by the British Banking Association or the federal funds effective rate published by the Federal Reserve Bank of New York plus 0.50%. In February 2013, ATI also entered into an additional amendment with the term loan lenders under its Senior Secured Credit Facility to extend the maturity of \$411.4 million of term loan debt from August 2014 to August 2017 and to increase the applicable margin at the Company's option to either (a) 3.00% over the LIBOR or (b) 2.00% over the greater of the prime lending rate provided by the British Banking Association or the federal funds effective rate published by the Federal Reserve Bank of New York plus 0.50%. The February 2013 amendments were treated as a modification of debt under GAAP, and the Company expensed \$1.0 million of deferred financing fees and recorded \$1.6 million of new deferred financing fees in the consolidated financial statements.

In August 2013, ATI entered into an amendment with the term loan lenders under its Senior Secured Credit Facility to refinance \$1,139.3 million of term loan debt and decrease the applicable margin for such term loans at the Company's option to either (a) 2.75% or 2.50%, subject to the Company's total leverage ratio, over the LIBOR (which may not be less than 1.00%) or (b) 1.75% or 1.50%, subject to the Company's total leverage ratio, over the greater of the prime lending rate provided by the British Banking Association or the federal funds effective rate published by the Federal Reserve Bank of New York plus 0.50% (which may not be less than 2.00%). The amendment was treated as a modification of debt under GAAP, and thus the Company expensed \$2.1 million of deferred financing fees and recorded \$1.0 million of new deferred financing fees in the consolidated financial statements.

In December 2013, ATI entered into an amendment with the term loan lenders under its Senior Secured Credit Facility to extend the maturity of \$650.0 million of term loan debt from August 2017 to August 2019 and to reduce the applicable margin at the Company's option to either (a) 2.75% or 2.50%, subject to the Company's total leverage ratio, over the LIBOR (which may not be less than 1.00%) or (b) 1.75% or 1.50%, subject to the Company's total leverage ratio, over the greater of the prime lending rate provided by the British Banking Association or the federal funds effective rate published by the Federal Reserve Bank of New York plus 0.50% (which may not be less than 2.00%). The amendment also extended the maturity of the revolving credit facility to January 2019, increased the borrowing capacity to \$410.0 million, reduced the interest rate spread to either 2.25%, 2.00% or 1.75% on LIBOR loans or 1.25%, 1.00% or 0.75% on Base Rate loans, subject to the Company's total leverage ratio, reduced the commitment fee to either 0.375% or 0.25%, subject to the Company's total leverage ratio, and increased the letters of credit sublimit to \$75.0 million. Lastly, the amendment changed the requirement of the maximum total senior secured leverage ratio, so that it is only applicable to the revolving portion of the Senior Secured Credit Facility and is tested only when revolving commitments (including letters of credit) remain outstanding at the end of any fiscal quarter. The amendment to the term loans was treated as a modification of debt under GAAP, and thus the Company expensed \$0.5 million of deferred financing fees and recorded \$10.1 million of new deferred financing fees in the consolidated financial statements. The amendment to the revolving portion of the Senior Secured Credit Facility was treated as a modification of debt under GAAP, and thus the Company expensed \$0.4 million of deferred financing fees and recorded \$2.1 million of new deferred financing fees in the consolidated financial statements.

In April 2014, ATI entered into an amendment with the term loan lenders under its Senior Secured Credit Facility to refinance Term B-2 Loan. The interest rate margin applicable to such refinanced loan is at the Company's option, either (a) 2.75% over the LIBOR or (b) 1.75% over the greater of the prime lending rate provided by the British Banking Association or the federal funds effective rate published by the Federal Reserve Bank of New York plus 0.50%. The Company recorded \$0.3 million of new deferred financing fees in the condensed consolidated financial statements. As of December 31, 2014, these rates were approximately 2.92% and 3.75% on the Term B-2 Loan and Term B-3 Loan, respectively, and the weighted average rate on the Senior Secured Credit Facility was approximately 3.64%. The Senior Secured Credit Facility requires minimum quarterly principal payments on the Term B-2 Loan and Term B-3 Loan as well as prepayments from certain net cash proceeds of non-ordinary course asset sales and casualty and condemnation events and from a percentage of excess cash flow, if applicable. Due to voluntary prepayments, the Company has fulfilled all Term B-2 Loan required quarterly payments through its maturity date of 2017. During 2014, the Company made principal payments of \$140.0 million on the Term B-2 Loan, resulting in a loss of \$0.5 million associated with the write off of related deferred debt issuance costs. The minimum required quarterly principal payment on the Term B-3 Loan is \$4.5 million and remains through its maturity date of 2019. As of December 31, 2014, there had been no payments required for certain net cash proceeds of non-ordinary course asset sales and casualty and condemnation events. The remaining principal balance on each loan is due upon maturity.

The Senior Secured Credit Facility is collateralized by a lien on substantially all assets of the Company including all of ATI's capital stock and all of the capital stock or other equity interest held by the Company, ATI and each of the Company's existing and future U.S. subsidiary guarantors (subject to certain limitations for equity interests of foreign subsidiaries and other exceptions set forth in the terms of the Senior Secured Credit Facility).

In accordance with the Senior Secured Credit Facility, net cash proceeds of non-ordinary course asset sales, casualty and condemnation events will only be required to prepay the term loan if the Company does not reinvest or commit to reinvest such net cash proceeds in assets to be used in its business or to make certain other permitted investments within 15 months of the related transaction or event, subject to certain limitations. The Company must apply 50% of its annual excess cash flow (as defined in the Senior Secured Credit Facility) to the prepayment of the Senior Secured Credit Facility, however this percentage reduces to certain levels and eventually to zero upon achievement of certain total senior secured leverage ratios. For the year ended December 31, 2014 and 2013, the Company was not required to make an excess cash flow payment.

[Table of Contents](#)

The Senior Secured Credit Facility also provides for revolving credit borrowings. In 2014, ATI increased the revolving commitments available under the revolving portion of the Senior Secured Credit Facility to \$465.0 million, net of an allowance for up to \$75.0 million in outstanding letters of credit commitments. The increase was treated as a modification of debt under GAAP, and thus the Company recorded \$0.6 million of new deferred financing fees in the consolidated financial statements. As of December 31, 2014, the Company had \$455.1 million available under the revolving credit facility, net of \$9.9 million in letters of credit. During 2014, the Company made one withdrawal and payment on the revolving credit facility as part of its debt management plans. The maximum amount outstanding at any time during the year on the revolving credit facility was \$40.0 million, and the entire balance was repaid within the quarter it was borrowed. Revolving credit borrowings bear interest at a variable base rate plus an applicable margin based on the Company's total leverage ratio. As of December 31, 2014, this rate would have been approximately 1.92%. In addition, there is an annual commitment fee, based on the Company's total leverage ratio, which as of December 31, 2014, was equal to 0.25% of the average unused revolving credit borrowings available under the Senior Secured Credit Facility. Revolving credit borrowings are payable at the option of the Company throughout the term of the Senior Secured Credit Facility with the balance due in January 2019.

The revolving portion of the Senior Secured Credit Facility requires the Company to maintain a specified maximum total senior secured leverage ratio of 5.50x when revolving loan commitments remain outstanding at the end of a fiscal quarter. On March 12, 2014, however, the revolving lenders holding a majority of the revolving loan commitments permanently waived and agreed that no event of default would result from any non-compliance so long as there were no revolving loans outstanding as of the last day of any fiscal quarter. As of December 31, 2014, the Company had no revolving loans outstanding; however the Company would have been in compliance with the maximum total senior secured leverage ratio, achieving a 2.42x ratio. Additionally within the terms of the Senior Secured Credit Facility, a senior secured leverage ratio at or below 3.50x results in the elimination of excess cash flow payments on the Senior Secured Credit Facility for the applicable year. The Senior Secured Credit Facility also provides certain financial incentives based on our total leverage ratio. A total leverage ratio at or below 4.00x results in a 25 basis point reduction to the applicable margin on the revolving credit facility, and a total leverage ratio at or below 3.50x results in a 12.5 basis point reduction to the revolving credit facility commitment fee and an additional 25 basis point reduction to the applicable margin on the revolving credit facility. A total leverage ratio at or below 3.25x results in a 25 basis point reduction to the applicable margin on our Term B-3 Loan. These reductions would remain in effect as long as the Company achieves a total leverage ratio at or below the related threshold. As of December 31, 2014, the total leverage ratio was 3.05x.

In addition, the Senior Secured Credit Facility, among other things, includes customary restrictions (subject to certain exceptions) on the Company's ability to incur certain indebtedness, grant certain liens, make certain investments, declare or pay certain dividends, or repurchase shares of the Company's common stock. As of December 31, 2014, the Company is in compliance with all covenants under the Senior Secured Credit Facility.

Senior Notes

In May 2011, the Company completed an offering of \$500.0 million of the 7.125% Senior Notes. The Company may from time to time seek to retire the 7.125% Senior Notes through cash purchases and/or exchanges for equity securities, in open market purchases, privately negotiated transactions, contractual redemptions or otherwise. Such repurchases or exchanges, if any, will depend on prevailing market conditions, liquidity requirements, contractual restrictions and other factors. The amounts involved may be material. Prior to May 15, 2015, the Company may redeem some or all of the 7.125% Senior Notes by paying the applicable "make-whole" premium. At any time on or after May 15, 2015, the Company may redeem some or all of the 7.125% Senior Notes at specified redemption prices in the governing indenture.

The 7.125% Senior Notes are unsecured and guaranteed by the subsidiaries that guarantee the Senior Secured Credit Facility and will be unconditionally guaranteed, jointly and severally, by any future domestic subsidiaries that guarantee the Senior Secured Credit Facility. The indenture governing the 7.125% Senior Notes contains negative covenants restricting or limiting the Company's ability to, among other things: incur or guarantee additional indebtedness, incur liens, pay dividends on, redeem or repurchase the Company's capital stock, make certain investments, permit payment or dividend restrictions on certain of the Company's subsidiaries, sell assets, engage in certain transactions with affiliates, and consolidate or merge or sell all or substantially all of the Company's assets. Certain of these covenants would be suspended if the 7.125% Senior Notes were to reach investment grade.

NOTE 8. DERIVATIVES

The Company is exposed to certain financial risk from volatility in interest rates, foreign exchange rates and commodity prices. The risk is managed through the use of financial derivative instruments including interest rate swaps, foreign currency forward contracts and commodity swaps. The Company's current derivative instruments are used strictly as an economic hedge and not for speculative purposes. As necessary, the Company adjusts the values of the derivative instruments for counter-party or credit risk.

Interest Rate

The Company is subject to interest rate risk related to the Senior Secured Credit Facility and enters into interest rate swap contracts that are based on the LIBOR to manage a portion of this exposure. The Company has not elected hedge accounting treatment for these derivatives, and as a result, fair value adjustments are charged directly to Interest expense in the Consolidated Statements of Comprehensive Income. A summary of the Company's interest rate derivatives as of December 31, 2014 and December 31, 2013 follows (dollars in millions):

	December 31, 2014		December 31, 2013	
	Notional Amount	Fair Value	Notional Amount	Fair Value
3.75% Interest Rate Swap H, Aug 2011 – Aug 2014	\$ —	\$ —	\$ 350.0	\$ (7.2)
3.77% Interest Rate Swap I, Aug 2011 – Aug 2014	—	—	350.0	(7.2)
2.96% Interest Rate Swap J, Aug 2013 – Aug 2014	—	—	125.0	(2.0)
3.05% Interest Rate Swap K, Aug 2013 – Aug 2014	—	—	125.0	(2.0)
3.44% Interest Rate Swap L, Aug 2016 – Aug 2019*	75.0	(2.3)	75.0	(0.4)
3.43% Interest Rate Swap M, Aug 2016 – Aug 2019*	100.0	(3.0)	100.0	(0.4)
3.37% Interest Rate Swap N, Aug 2016 – Aug 2019*	75.0	(2.1)	75.0	(0.2)
3.19% Interest Rate Swap O, Aug 2016 – Aug 2019*	75.0	(1.7)	75.0	0.2
3.08% Interest Rate Swap P, Aug 2016 – Aug 2019*	75.0	(1.5)	75.0	0.4
2.99% Interest Rate Swap Q, Aug 2016 – Aug 2019*	50.0	(0.9)	50.0	0.4
2.98% Interest Rate Swap R, Aug 2016 – Aug 2019*	50.0	(0.9)	50.0	0.4
2.73% Interest Rate Swap S, Aug 2016 – Aug 2019*	50.0	(0.5)	—	—
2.74% Interest Rate Swap T, Aug 2016 – Aug 2019*	75.0	(0.8)	—	—
2.66% Interest Rate Swap U, Aug 2016 – Aug 2019*	50.0	(0.4)	—	—
2.60% Interest Rate Swap V, Aug 2016 – Aug 2019*	50.0	(0.3)	—	—
2.40% Interest Rate Swap W, Aug 2016 – Aug 2019*	25.0	0.0	—	—
* includes LIBOR floor of 1.00%	\$ 750.0	\$ (14.4)	\$1,450.0	\$ (18.0)

As of December 31, 2014, the Company did not have any interest rate derivatives subject to credit-risk or collateral requirement. As of December 31, 2013, certain of the Company's interest rate derivatives contained credit-risk and collateral contingent features under which downgrades in the Company's credit rating would have required the Company to increase its collateral. As of December 31, 2013, certain interest rate derivatives also contained provisions under which the Company was required to post additional collateral if the LIBOR interest rate curve reached certain levels.

As of December 31, 2014 and December 31, 2013, the Company had recorded cash collateral of \$0.0 million and \$1.7 million, respectively, in Other current assets in the Condensed Consolidated Balance Sheets, as the balances are subject to frequent change.

Currency Exchange

The Company's business is subject to foreign exchange rate risk. As a result, the Company enters into various forward rate contracts that qualify as derivatives under the authoritative accounting guidance to manage certain of these exposures. Forward contracts are used to hedge forecasted transactions and known exposure of payables denominated in a foreign currency. The Company generally has not elected to apply hedge accounting under the authoritative accounting guidance and recorded the unrealized fair value adjustments and realized gains and losses associated with these contracts in Other expense, net in the Consolidated Statements of Comprehensive Income during the period of change.

The following table summarizes the outstanding foreign currency forward contracts as of December 31, 2014 and 2013 (amounts in millions):

	December 31, 2014		December 31, 2013	
	Notional Amount	Fair Value	Notional Amount	Fair Value
Japanese Yen (JPY)	¥ 300.0	\$ (0.3)	¥ 600.0	\$ (0.3)
		\$ (0.3)		\$ (0.3)

[Table of Contents](#)

Commodity

The Company's business is subject to commodity price risk, primarily with component suppliers. As a result, the Company enters into various commodity swap contracts that qualify as derivatives under the authoritative accounting guidance to manage certain of these exposures. Swap contracts are used to hedge forecasted transactions either of the commodity or of components containing the commodity. The Company has not qualified for hedge accounting treatment for these commodity contracts, and as a result, unrealized fair value adjustments and realized gains and losses associated with these contracts were charged directly to Other expense, net in the Consolidated Statements of Comprehensive Income during the period of change.

The following table summarizes the outstanding commodity swaps as of December 31, 2014 and December 31, 2013 (dollars in millions):

	December 31, 2014			December 31, 2013		
	Notional Amount	Quantity	Fair Value	Notional Amount	Quantity	Fair Value
Aluminum	\$ 11.3	6,200 metric tons	\$ (0.7)	\$ 23.8	11,875 metric tons	\$ (1.6)
Natural Gas	\$ 0.2	60,000 MMBtu	0.0	\$ 0.3	90,000 MMBtu	0.0
			<u>\$ (0.7)</u>			<u>\$ (1.6)</u>

The following tabular disclosures further describe the Company's derivative instruments and their impact on the financial condition of the Company (dollars in millions):

	December 31, 2014		December 31, 2013	
	Balance Sheet Location	Fair Value	Balance Sheet Location	Fair Value
Derivatives not designated as hedging instruments				
Foreign currency contracts	Other current liabilities	\$ (0.3)	Other current liabilities	\$ (0.3)
Commodity contracts			Other current and non-current assets	0.1
	Other current and non-current liabilities	(0.7)	Other current and non-current liabilities	(1.7)
Interest rate contracts			Other non-current assets	1.5
	Other non-current liabilities	(14.4)	Other current and non-current liabilities	(19.5)
Total derivatives not designated as hedging instruments		<u>\$ (15.4)</u>		<u>\$ (19.9)</u>

The fair values of the derivatives are recorded between Other current and non-current assets and Other current and non-current liabilities as appropriate in the Consolidated Balance Sheets. As of December 31, 2014, the amount recorded to Other current liabilities for foreign currency contracts was (\$0.3) million. The amounts recorded to Other current and non-current liabilities for commodity contracts were (\$0.6) million and (\$0.1) million, respectively. The amounts recorded to Other non-current liabilities for interest rate contracts were (\$14.4) million, respectively.

As of December 31, 2013, the amount recorded to Other current liabilities for foreign currency contracts was (\$0.3) million. The amounts recorded to Other current and non-current assets for commodity contracts were \$0.1 million and \$0.0 million, respectively. The amounts recorded to Other current and non-current liabilities for commodity contracts were (\$1.5) million and (\$0.2) million, respectively. The amount recorded to Other non-current assets for interest rate contracts was \$1.5 million. The amounts recorded to Other current and non-current liabilities for interest rate contracts were (\$18.5) million and (\$1.0) million, respectively.

The impact on the Company's Consolidated Statements of Comprehensive Income related to foreign currency and commodity contracts can be found in NOTE 11, and the following tabular disclosure describes the location and impact on the Company's results of operations related to unrealized gain (loss) on interest rate derivatives (dollars in millions):

	December 31, 2014	December 31, 2013	December 31, 2012
Location of impact on results of operations			
Interest expense	\$ 3.5	\$ 34.3	\$ 25.5

NOTE 9. PRODUCT WARRANTY LIABILITIES

Product warranty liability activities consist of the following (dollars in millions):

	Year ended December 31, 2014	Year ended December 31, 2013	Year ended December 31, 2012
Beginning balance	\$ 90.5	\$ 109.7	\$ 115.4
Payments	(35.0)	(38.7)	(47.3)
Increase in liability (warranty issued during period)	26.8	28.4	25.5
Net adjustments to liability	0.7	(9.6)	15.3
Accretion (for Predecessor liabilities)	0.6	0.7	0.8
Ending balance	<u>\$ 83.6</u>	<u>\$ 90.5</u>	<u>\$ 109.7</u>

As of December 31, 2014, the current and non-current product warranty liabilities were \$24.0 million and \$59.6 million, respectively. As of December 31, 2013, the current and non-current product warranty liabilities were \$37.4 million and \$53.1 million, respectively.

During June 2007, Old GM recognized the estimated cost of replacing the Dual Power Inverter Module (“DPIM”) used on H 40/50 EP hybrid systems. Certain units were falling short of their expected service life and Allison Transmission (the “Predecessor”), an operating unit of General Motors Corporation, decided to cover repair or replacement for an extended period. The Company is responsible for the first \$12.0 million of qualified cost while General Motors Company (“GM”) is responsible for the next \$34.0 million of costs, with any amount over \$46.0 million being shared one-third by the Company and two-thirds by GM for shipments through June 30, 2009.

During 2014, the Company completed an analysis of its DPIM extended coverage program and determined, based on current claims, that the product warranty liability should be increased by \$3.9 million. This resulted in a \$2.9 million increase in the GM DPIM receivable and a \$1.0 million unfavorable adjustment to the Consolidated Statements of Comprehensive Income. As of December 31, 2014, the DPIM liability was \$48.5 million with an associated receivable from GM of \$28.7 million. Through December 31, 2014, the Company had paid approximately \$32.8 million in DPIM claims and received approximately \$14.9 million in reimbursement from GM. The Company will continue to review the total DPIM liability and GM receivable for any changes in estimates as additional data becomes available.

During 2013, the Company completed an analysis of its DPIM extended coverage program and determined, based on current claims, that the product warranty liability should be reduced by \$8.2 million. This resulted in a \$5.8 million reduction in the GM DPIM receivable and a \$2.4 million favorable adjustment to the Consolidated Statements of Comprehensive Income. As of December 31, 2013, the DPIM liability was \$44.6 million with an associated receivable from GM of \$25.8 million. Through December 31, 2013, the Company had paid approximately \$25.5 million in DPIM claims and received approximately \$9.1 million in reimbursement from GM.

During 2012, the Company completed an analysis of its DPIM extended coverage program and determined, based on current claims, that the product liability should be reduced by \$7.9 million. This resulted in a \$7.3 million reduction in the GM DPIM receivable and a \$0.6 million favorable adjustment to the Consolidated Statements of Comprehensive Income. As part of the analysis, it was also determined that design issues related to the early introduction of the replacement DPIM unit resulted in a \$10.0 million increase to the product warranty liability. As the replacement DPIM unit is the responsibility of the Company and not covered by the asset purchase agreement dated June 28, 2007 (“Asset Purchase Agreement”), the Company recorded a \$10.0 million charge to the Consolidated Statements of Comprehensive Income.

The remaining adjustments to the total liability in 2014, 2013 and 2012 were the result of general changes in estimates for various products as additional claims data and field information became available.

NOTE 10. DEFERRED REVENUE

As of December 31, 2014, the current and non-current deferred revenue for Extended Transmission Coverage (“ETC”) were \$20.3 million and \$48.7 million, respectively. As of December 31, 2013, the current and non-current deferred revenue for ETC were \$20.4 million and \$43.2 million, respectively.

Deferred revenue for ETC activity (dollars in millions):

	Year ended December 31, 2014	Year ended December 31, 2013	Year ended December 31, 2012
Beginning balance	\$ 63.6	\$ 63.5	\$ 60.5
Increases	26.2	21.1	22.9
Revenue earned	(20.8)	(21.0)	(19.9)
Ending balance	<u>\$ 69.0</u>	<u>\$ 63.6</u>	<u>\$ 63.5</u>

Deferred revenue recorded in current liabilities related to unearned net sales for defense contracts for the years ended December 31, 2014, 2013 and 2012 was approximately \$0.3 million, \$8.8 million and \$0.7 million, respectively.

Due to requests from the U.S. government, the Company billed, but did not ship certain tracked transmissions during 2013. Based on the lack of a fixed delivery date from the U.S. government, the Company deferred approximately \$8.8 million of net sales for these transmissions until they were shipped in 2014.

NOTE 11. OTHER EXPENSE, NET

Other expense, net consists of the following (dollars in millions):

	Years ended December 31,		
	2014	2013	2012
Loss on intercompany foreign exchange	\$(5.4)	\$ (2.3)	\$ —
Grant program income	2.6	5.2	11.5
Impairment loss on investments in technology-related initiatives	(2.0)	(5.0)	(14.4)
Gain on negotiation of commercial agreement	2.0	—	—
Public offering fees and expenses	(1.4)	(1.6)	(6.1)
Unrealized gain (loss) on derivative contracts (see NOTE 8)	1.2	(1.5)	0.9
Realized loss on derivative contracts (see NOTE 8)	(1.0)	(2.8)	(1.3)
Loss on foreign exchange	(1.0)	(2.4)	(2.6)
Loss on repayments and repurchases of long-term debt (see NOTE 7)	(0.5)	(0.8)	(22.1)
Termination of services agreement	—	—	(16.0)
Loss on re-measurement of employee benefit plans (see NOTE 13)	—	—	(2.3)
Other	(0.1)	0.3	(0.4)
Total	<u>\$(5.6)</u>	<u>\$(10.9)</u>	<u>\$(52.8)</u>

During 2014 and 2013, the Company recorded a loss of \$5.4 and \$2.3 million, respectively, resulting from intercompany financing transactions related to investments in plant assets for the Company’s India facility.

During 2014, the Company fulfilled its obligations to the U.S. Department of Energy related to the development of hybrid-propulsion systems manufacturing capacity in the U.S. (the “Grant Program”). All applicable costs associated with the Grant Program have been charged to Engineering — research and development while the Government’s matching reimbursement was recorded to Other expense, net in the Consolidated Statements of Comprehensive Income.

For the years ended December 31, 2014, 2013 and 2012, the Company made \$2.0 million, \$5.0 million and 14.4 million investments as part of an agreement to expand our position in transmission technologies. Due to various uncertainties surrounding the investments including, but not limited to, the startup nature of the underlying business, its continued negative cash flow, undercapitalization and unproven business plan, the Company has impaired the investments to zero as of December 31, 2014, 2013 and 2012.

NOTE 12. OTHER CURRENT LIABILITIES

Other current liabilities consist of the following (dollars in millions):

	As of December 31, 2014	As of December 31, 2013
Payroll and related costs	\$ 50.9	\$ 32.7
Sales allowances	25.5	26.9
Defense price reduction reserve	16.2	26.8
Vendor buyback obligation	13.2	11.8
Taxes payable	8.5	8.6
Accrued interest payable	5.2	11.2
Derivative liabilities	0.8	20.2
Other accruals	11.4	14.1
Total	<u>\$ 131.7</u>	<u>\$ 152.3</u>

NOTE 13. EMPLOYEE BENEFIT PLANS

The Company's hourly defined benefit pension plan generally provides benefits of negotiated, stated amounts for each year of service as well as significant supplemental benefits for employees who retire with 30 years of service before normal retirement age. For all hourly employees hired after May 18, 2008, the defined benefit pension plan was replaced with a defined contribution pension plan, and the company-sponsored retiree healthcare was also eliminated for those hired after May 18, 2008. The charge to expense for the hourly defined contribution pension plan was \$1.3 million, \$1.0 million and \$0.9 million for the years ended December 31, 2014, 2013 and 2012, respectively.

In accordance with the Asset Purchase Agreement, the Company's hourly employees who retired prior to October 2, 2011 (the "Cutoff Date") will have their pension and OPEB paid by GM. The Company was required, pursuant to the Asset Purchase Agreement, to transfer pension assets to GM's pension plan to cover the Company's portion of its pension liability related to the employees who retired prior to the Cutoff Date. During the second quarter of 2012, the Company completed the transfer of its pension obligation for certain qualified hourly employees to GM's pension plan. The transfer required a re-measurement of the hourly defined benefit pension plan resulting in a one-time non-cash settlement charge of \$2.3 million recorded in Other expense, net in the Consolidated Statements of Comprehensive Income and a \$4.2 million reduction to the Company's pension liability with corresponding adjustments to AOCL, net of tax. This resulted in a \$17.9 million gain to the Company's 2011 actuarial valuation. Employees that retire subsequent to the Cutoff Date will have their Allison pension and OPEB paid by the Company and their GM pension benefit paid by GM.

The Company's salaried defined benefit plan covering salaried employees with a service date prior to January 1, 2001 is generally based on years of service and compensation history. The salaried defined contribution retirement savings plan requires the Company to match employee contributions up to certain predefined limits based upon eligible base salary. In addition to the matching contribution, the Company is required to make a contribution equal to 1% of eligible base salary for salaried employees with a service date on or after January 1, 1993 to cover certain benefits in retirement that are different from salaried employees with a service date prior to January 1, 1993. In addition, for salaried employees with a service date on or after January 1, 2001, the Company is required to contribute to its defined contribution retirement savings plan an amount equal to 4% of eligible base salary under the program. The charge to expense for the salaried defined contribution retirement savings plan was \$5.4 million, \$5.4 million and \$5.1 million for the years ended December 31, 2014, 2013 and 2012, respectively.

The Company is also responsible for OPEB costs (medical, dental, vision, and life insurance) for hourly employees hired prior to May 19, 2008. Post-retirement benefit costs consist of service cost, interest cost on accrued obligations and the expected return on assets (calculated using a smoothed market value of assets). Any difference between actual and expected returns on assets during a year and actuarial gains and losses on liabilities together with any prior service costs are charged (or credited) to income over the average remaining service lives of employees. The benefit cost components shown in the Consolidated Statements of Comprehensive Income are based upon certain data specific to the Company, actuarial assumptions that were used for OPEB accounting disclosures, and certain allocation methodologies such as population demographics. The plan is unfunded and any future payments will be funded by the Company's operating cash flows. As of December 31, 2014 and 2013, the Company had an estimated OPEB liability for hourly employees hired prior to May 19, 2008, excluding those employees eligible to retire at the time of the sale of the Company ("the Acquisition Transaction"), of \$136.0 million and \$120.7 million, respectively.

[Table of Contents](#)

As part of the Health Care Reform Act enacted in 2010, the Company has evaluated the impact on “High-cost Health Plans” in which employers offering health plan coverage exceeding certain thresholds must pay an excise tax equal to 40% of the value of the plan that exceeds the threshold amount. Although the excise tax does not come into effect until 2018, the Company has recorded \$4.0 million in its OPEB liability as of December 31, 2014 with a corresponding adjustment to AOCL, net of tax.

The Company provides contributions to certain international benefit plans; however, these contributions are not material for periods presented.

For all pension and OPEB plans in which employees participate, costs are determined within the FASB’s authoritative accounting guidance set forth on employers’ defined benefit pensions including accounting for settlements and curtailments of defined benefit pension plans, termination of benefits and accounting for post-retirement benefits other than pensions. In accordance with the authoritative accounting guidance, the Company recognizes the funded status of its defined benefit pension plans and OPEB plan in its Consolidated Balance Sheets with a corresponding adjustment to AOCL, net of tax.

Information about the net periodic benefit cost and other changes recognized in AOCL for the pension and post-retirement benefit plans is as follows (dollars in millions):

	Pension Plans			Post-retirement Benefits		
	Year ended December 31, 2014	Year ended December 31, 2013	Year ended December 31, 2012	Year ended December 31, 2014	Year ended December 31, 2013	Year ended December 31, 2012
Net Periodic Benefit Cost:						
Service cost	\$ 13.2	\$ 16.3	\$ 15.2	\$ 2.2	\$ 3.3	\$ 3.9
Interest cost	5.0	4.0	4.1	5.9	5.8	7.2
Expected return on assets	(7.7)	(6.7)	(5.9)	—	—	—
Prior service cost	0.1	0.1	0.1	(3.6)	(3.6)	—
Loss (gain)	—	0.7	1.2	(0.7)	—	—
Settlement loss	—	—	2.3	—	—	—
Net Periodic Benefit Cost	\$ 10.6	\$ 14.4	\$ 17.0	\$ 3.8	\$ 5.5	\$ 11.1
Other changes recognized in other comprehensive income:						
Prior service credit	\$ —	\$ —	\$ —	\$ —	\$ —	\$ (28.9)
Net loss (gain)	2.1	(18.4)	(2.1)	7.8	(30.7)	3.8
Amortizations	(0.1)	(0.8)	(3.6)	4.3	3.6	—
Total recognized – other comprehensive income	\$ 2.0	\$ (19.2)	\$ (5.7)	\$ 12.1	\$ (27.1)	\$ (25.1)

The table below provides the weighted-average actuarial assumptions used to determine the net periodic benefit cost.

	Pension Plans			Post-retirement Benefits		
	Year ended December 31, 2014	Year ended December 31, 2013	Year ended December 31, 2012	Year ended December 31, 2014	Year ended December 31, 2013	Year ended December 31, 2012
Discount rate	4.80%	3.90%	4.60%	4.90%	4.10%	4.60%
Rate of compensation increase (salaried)	3.00%	3.00%	4.00%	N/A	N/A	N/A
Expected return on assets	6.80%	7.00%	7.00%	N/A	N/A	N/A

The table below provides the weighted-average actuarial assumptions used to determine the benefit obligations of the Company’s plans.

	Pension Plans		Post-retirement Benefits	
	As of December 31,			
	2014	2013	2014	2013
Discount rate	3.90%	4.80%	4.00%	4.90%
Rate of compensation increase (salaried)	3.00%	3.00%	N/A	N/A

Table of Contents

The Company's pension and OPEB costs are calculated using various actuarial assumptions and methodologies as prescribed by authoritative accounting guidance. These assumptions include discount rates, expected return on plan assets, health care cost trend rates, inflation, rate of compensation increases, mortality rates and other factors. The Company reviews all actuarial assumptions on an annual basis.

The discount rate is used to determine the present value of the Company's benefit obligations. The Company's discount rate is determined by matching the plans projected cash flows to a yield curve based on long-term, fixed income debt instruments available as of the measurement date of December 31, 2014.

The overall expected rate of return on plan assets is based upon historical and expected future returns consistent with the expected benefit duration of the plan for each asset group adjusted for investment and administrative fees.

During 2014, the Society of Actuaries finalized a new mortality table and a new mortality improvement scale that increased the anticipated longevity of life. As of December 31, 2014, as a result of the updated mortality assumption, the Company recorded an additional \$2.9 million and \$4.1 million in its defined benefit pension benefit obligation and OPEB obligation, respectively.

Health care cost trends are used to project future post-retirement benefits payable from the Company's plans. For the Company's December 31, 2014 obligations, future post-retirement medical care costs were forecasted assuming an initial annual increase of 6.70%, decreasing to 4.50% by the year 2027. Future post-retirement prescription drug costs were forecasted assuming an initial annual increase of 6.00%, decreasing to 4.50% by the year 2027.

As health care costs trends have a significant effect on the amounts reported, an increase and decrease of one-percentage-point would have the following effects in the year ended December 31, 2014 (dollars in millions):

	1% Increase	1% Decrease
Effect on total of service and interest cost	\$ 1.7	\$ (1.3)
Effect on post-retirement benefit obligation	\$ 28.6	\$ (22.3)

The following table provides a reconciliation of the changes in the net benefit obligations and fair value of plan assets for the years ended December 31, 2014, 2013 and 2012 (dollars in millions):

	Pension Plans			Post-retirement Benefits		
	Year ended December 31, 2014	Year ended December 31, 2013	Year ended December 31, 2012	Year ended December 31, 2014	Year ended December 31, 2013	Year ended December 31, 2012
Benefit Obligations:						
Net benefit obligation at beginning of year	\$ 105.9	\$ 103.3	\$ 99.7	\$ 120.7	\$ 142.6	\$ 156.6
Service cost	13.2	16.3	15.2	2.2	3.3	3.9
Interest cost	5.0	4.0	4.1	5.9	5.8	7.2
Plan Amendments	—	—	—	—	—	(28.9)
Settlements	—	—	(18.8)	—	—	—
Benefits paid	(1.5)	(0.8)	(0.4)	(0.6)	(0.3)	—
Actuarial loss (gain)	10.9	(16.9)	3.5	7.8	(30.7)	3.8
Net benefit obligation at end of year	<u>\$ 133.5</u>	<u>\$ 105.9</u>	<u>\$ 103.3</u>	<u>\$ 136.0</u>	<u>\$ 120.7</u>	<u>\$ 142.6</u>
Fair Value of Plan Assets:						
Fair value of plan assets at beginning of year	\$ 108.6	\$ 89.4	\$ 83.4	\$ —	\$ —	\$ —
Actual return on plan assets	16.4	8.2	11.5	—	—	—
Employer contributions	11.8	11.8	13.7	0.6	0.3	—
Settlements	—	—	(18.8)	—	—	—
Benefits paid	(1.5)	(0.8)	(0.4)	(0.6)	(0.3)	—
Fair value of plan assets at end of year	<u>\$ 135.3</u>	<u>\$ 108.6</u>	<u>\$ 89.4</u>	<u>\$ —</u>	<u>\$ —</u>	<u>\$ —</u>
Net Funded Status	<u>\$ 1.8</u>	<u>\$ 2.7</u>	<u>\$ (13.9)</u>	<u>\$ (136.0)</u>	<u>\$ (120.7)</u>	<u>\$ (142.6)</u>

[Table of Contents](#)

In the second quarter of 2012, the Company completed its negotiation with GM to determine the amount of pension assets to be transferred from the Company to GM as required by the Asset Purchase Agreement. The Company transferred \$18.8 million of plan assets to GM to settle this obligation.

In the fourth quarter of 2012, the Company and the International Union, United Automobile, Aerospace and Agricultural Implement Workers of America (“UAW”) Local 933 entered into a new five year collective bargaining agreement that expires in November 2017. The multi-tiered wage and benefit structure from the prior agreement was retained and the parties agreed to additional changes, such as implementing a new retirement health care plan and eliminating the consumer price index based cost of living allowance that had been part of the prior agreement. As a result, the Company recorded a \$28.9 million favorable adjustment to the net benefit obligation.

The Company’s pension plan assets consist of money market funds, mutual funds and listed equities. The Company’s valuation techniques used to fair value pension plan assets represents a market approach in active markets for identical assets that qualifies as Level 1 in the fair value hierarchy.

The fair values of plan assets for the Company’s pension plans as of December 31, 2014 and 2013 are as follows (dollars in millions):

Asset Category	Quoted Prices in Active Markets for Identical Assets (Level 1)			
	2014		2013	
	Fair Value	%	Fair Value	%
Cash and cash equivalents	\$ 8.6	6%	\$ 3.6	3%
Diversified equity securities	57.8	43	51.5	48
Diversified debt securities	68.9	51	53.5	49
Total	\$ 135.3	100%	\$ 108.6	100%

The Company’s investment strategy with respect to pension plan assets is to invest the assets in accordance with laws and regulations. The long-term primary objectives for the Company’s pension assets are to provide results that meet or exceed the plans’ actuarially assumed long-term rate of return without subjecting the funds to undue risk. To achieve these objectives the Company has established the following targets:

Asset Category	Target	
	Hourly	Salary
Cash and cash equivalents	5%	8%
Diversified equity securities	39	46
Diversified debt securities	56	46
Total	100%	100%

Through 2014, the Company’s investment committee has continued to evaluate the investments and take steps toward the established targets.

The following table discloses the amounts recognized in the balance sheet and in AOCL at December 31, 2014 and 2013, on a pre-tax basis (dollars in millions):

	Pension Plans		Post-retirement Benefits	
	As of December 31,			
	2014	2013	2014	2013
Amounts Recognized in Balance Sheet:				
Noncurrent assets	\$ 7.9	\$ 7.4	\$ —	\$ —
Current liabilities	—	—	(1.2)	(1.4)
Noncurrent liabilities	(6.1)	(4.7)	(134.8)	(119.3)
Total asset (liability)	\$ 1.8	\$ 2.7	\$ (136.0)	\$ (120.7)
Accumulated Other Comprehensive Loss:				
Prior service (cost) credit	\$ (0.1)	\$ (0.2)	\$ 21.7	\$ 25.4
Actuarial gain	0.6	2.7	8.6	17.1
Total	\$ 0.5	\$ 2.5	\$ 30.3	\$ 42.5

Table of Contents

The amounts in AOCL expected to be amortized and recognized as a component of net periodic benefit cost in 2015 are as follows (dollars in millions):

	2015	
	Pension Plans	Post-retirement Benefits
Prior service (cost) credit	\$ (1.0)	\$ 3.6
Actuarial loss	1.0	—
Total	\$ 0.0	\$ 3.6

The accumulated benefit obligation for the Company's pension plans as of December 31, 2014 and 2013 was \$129.7 million and \$103.1 million, respectively.

As of December 31, 2014 and 2013, the projected benefit obligation, the accumulated benefit obligation, and the fair value of plan assets for pension plans with a projected benefit obligation in excess of plan assets and for pension plans with an accumulated benefit obligation in excess of plan assets were as follows (dollars in millions):

	Hourly Plan		Salary Plan	
	As of December 31,			
	2014	2013	2014	2013
Plans with projected benefit obligation in excess of plan assets:				
Projected benefit obligation	N/A ¹	N/A ¹	\$71.4	\$53.8
Fair value of plan assets	N/A ¹	N/A ¹	\$65.3	\$49.1
Plans with accumulated benefit obligation in excess of plan assets:				
Accumulated benefit obligation	N/A ¹	N/A ¹	\$67.6	\$50.9
Fair value of plan assets	N/A ¹	N/A ¹	\$65.3	\$49.1

¹ As of December 31, 2014 and 2013, the hourly defined benefit pension plan had plan assets greater than both the projected benefit obligation and accumulated benefit obligation.

Information about expected cash flows for the Company's pension and post-retirement benefit plans is as follows (dollars in millions):

	Pension Plans	Post-retirement Benefits
Employer Contributions:		
2015 expected contributions	\$ 2.0	\$ 1.2
Expected Benefit Payments:		
2015	2.3	1.2
2016	3.0	1.7
2017	3.8	2.4
2018	4.6	3.2
2019	5.5	3.9
2020-2024	40.6	27.7

Expected benefit payments for pension and post-retirement benefits will be paid from plan trusts or corporate assets. The Company's funding policy is to contribute amounts annually that are at least equal to the amounts required by applicable laws and regulations or to directly fund payments to plan participants. Additional discretionary contributions will be made when deemed appropriate to meet the Company's long-term obligation to the plans.

In June 2012, the Company established a non-qualified deferred compensation plan ("Deferred Compensation Plan") for a select group of management. Under the terms of the plan, the Company has utilized a rabbi trust to accumulate assets to fund its promise to pay benefits under the Deferred Compensation Plan. The rabbi trust is an irrevocable trust, which restricts any use of funds (operational or otherwise) by the Company other than to pay benefits under the Deferred Compensation Plan, and prevents immediate taxation of contributed amounts. Funds are accumulated through both employee deferrals and a company match. Funds can be invested by the employee into a diversified group of investment options, which have been selected by the Company's investment committee, that are all categorized as Level 1 in the fair value hierarchy. The company match resulted in a charge of \$0.2 million, \$0.3 million, and \$0.1 million to the Consolidated Statements of Comprehensive Income for the years ended December 31, 2014, 2013 and 2012, respectively, and the fair value of the rabbi trust plan assets and deferred compensation obligation was \$2.9 million and \$1.3 million as of December 31, 2014 and 2013, respectively.

NOTE 14. STOCK-BASED COMPENSATION

In March 2012, the Company's Board of Directors adopted and the Company's stockholders approved the Allison Transmission Holdings, Inc. 2011 Equity Incentive Award Plan ("2011 Plan"), which became effective as of the day prior to the consummation of the Company's initial public offering. Under the 2011 Plan, certain employees (including executive officers), consultants and directors are eligible to receive equity-based compensation, including non-qualified stock options, incentive stock options, restricted stock, dividend equivalents, stock payments, restricted stock units ("RSU"), performance awards, stock appreciation rights and other equity-based awards, or any combination thereof. The 2011 Plan limits the aggregate number of shares of common stock available for issue to 15.3 million and will expire on, and no option or other equity award may be granted pursuant to the 2011 Plan after, the tenth anniversary of the date the 2011 Plan was approved by the Board of Directors.

Prior to the adoption of the 2011 Plan, the Company's equity-based awards were granted under the Equity Incentive Plan of Allison Transmission Holdings, Inc. ("Prior Plan"). As of the effective date of the 2011 Plan, no new awards will be granted under the Prior Plan, but the Prior Plan will continue to govern the equity awards issued under the Prior Plan.

Restricted Stock Units

RSUs were issued to certain employees in 2014, 2013 and 2012, and certain directors in 2014 and 2013 under the 2011 Plan at fair market value at the date of grant. These awards entitle the holder to receive one common share for each RSU upon vesting, which generally occurs over either one, two or three years upon continued performance of services by the RSU holders. A summary of RSU activity as of December 31, 2014, 2013 and 2012, and changes during the period then ended is presented below:

Non-vested RSUs:	RSUs (in millions)	Weighted-Average Grant-Date Fair Value
Non-vested as of December 31, 2011	—	\$ —
Granted	1.0	20.20
Vested	—	—
Forfeited	—	—
Non-vested as of December 31, 2012	1.0	\$ 20.20
Granted	0.2	23.31
Vested	(0.4)	20.23
Forfeited	—	—
Non-vested as of December 31, 2013	0.8	\$ 20.90
Granted	0.0	29.85
Vested	(0.6)	20.32
Forfeited	—	—
Non-vested as of December 31, 2014	0.2	\$ 26.57

As of December 31, 2014 and 2013, there were \$3.0 million and \$10.4 million, respectively, of unrecognized compensation cost related to non-vested RSU compensation arrangements granted under the 2011 Plan. This cost is expected to be recognized, on a straight line basis, over a period of approximately two years. RSU incentive compensation expense recorded was \$9.8 million, \$12.0 million and \$0.9 million for the years ended December 31, 2014, 2013 and 2012, respectively. The total fair value of RSUs vested during the years ended December 31, 2014, 2013 and 2012 was approximately \$20.2 million, \$9.0 million and \$0.0 million, respectively.

Pursuant to the share withholding provisions of the 2011 Plan and the related RSU award agreement, certain employees, in lieu of paying withholding taxes on the vesting of RSUs, authorized the withholding of an aggregate of approximately 0.3 million and 0.1 million shares, respectively of the Company's common stock to satisfy their minimum statutory tax withholding requirements related to such vesting events during 2014 and 2013. The withheld shares were recorded as a reduction to equity on the applicable vesting dates of approximately \$8.4 million and \$3.6 million during 2014 and 2013, respectively.

Restricted Stock

Restricted stock was granted to certain employees in 2014 under the 2011 Plan at fair market value on the date of grant. The restrictions lapse upon continued performance by the restricted stock holders on the vest date which generally occurs over one, two or three years. A summary of restricted stock activity as of December 31, 2014 and changes during the period then ended is presented below:

Non-vested Shares:	Restricted Stock (in millions)	Weighted-Average Grant-Date Fair Value
Non-vested as of December 31, 2013	—	\$ —
Granted	0.2	29.47
Vested	—	—
Forfeited	—	—
Non-vested as of December 31, 2014	0.2	\$ 29.47

As of December 2014, there was \$3.4 million of unrecognized compensation cost related to non-vested restricted stock compensation arrangements granted under the 2011 Plan. This cost is expected to be recognized, on a straight line basis, over a period of approximately 2 years. Restricted stock incentive compensation expense recorded was \$1.6 million for the year ended December 31, 2014.

Stock Options

Stock options granted under the Prior Plan after the completion of the Acquisition Transaction and through March 2012, have a per share exercise price based on the fair market value of the Company at the date of grant. Stock options granted under the 2011 Plan have a per share exercise price based on the closing price of a share of the Company’s common stock as reported by the NYSE on the date of grant. All stock options expire 10 years after the grant date. The options vest upon the continued performance of services by the option holder over time, with either 20% or 33% of the award vesting on each anniversary of the grant date over three to five years for awards under the Prior Plan and 100% in December of the year that is two years after the year of grant under the 2011 Plan. Upon termination of employment for reasons other than cause, retirement before the age of 65 with less than 90 points (calculated as age plus years of service), death or disability, the options shall cease to be exercisable ninety days following the date of the optionees’ termination of service. Upon termination of employment for cause, the options shall not be exercisable on the date of such termination. Upon termination of employment for retirement at or after the age of 65, the options shall cease to be exercisable three years following such date. Upon termination of employment for retirement before the age of 65 with 90 or more points, the options shall cease to be exercisable two years following such date. Upon termination of employment for death or disability, the options shall cease to be exercisable twelve months following such date.

In accordance with the FASB’s authoritative accounting guidance on stock compensation, each option grant is to be recorded at fair value. When options are granted, the Company uses a Black-Scholes option pricing model to calculate the fair value of each option award using the assumptions noted in the following table:

	2014	2013	2012
Expected volatility	38%	51%	N/A
Expected dividend yield	1.6%	1.2%	N/A
Expected term (in years)	5.5	5.4	N/A
Expected forfeitures	0%	0%	N/A
Risk-free rate	1.7%	1.6%	N/A

Expected volatility is based on “the average volatilities of otherwise similar public entities” as defined by authoritative accounting guidance. The Company currently pays a \$0.15 dividend per quarter. The expected term is derived from the average of the weighted vesting life and the contractual term. The risk-free rate for periods within the contractual life of the option is based on the U.S. Treasury yield curve in effect at the time of grant.

Table of Contents

A summary of option activity as of December 31, 2014, 2013 and 2012, and changes during the period then ended is presented below:

	Options (in millions)	Weighted- Average Exercise Price	Weighted-Average Remaining Contractual Term
Outstanding as of December 31, 2011	14.9	\$ 13.40	4.94 years
Exercisable as of December 31, 2011	11.5	\$ 13.37	4.88 years
Granted	—	—	
Exercised	(2.7)	—	
Forfeited or expired	(0.3)	—	
Outstanding as of December 31, 2012	11.9	\$ 14.01	4.93 years
Exercisable as of December 31, 2012	11.8	\$ 14.02	4.91 years
Granted	0.6	\$ 23.39	
Exercised	(3.8)	—	
Forfeited or expired	—	—	
Outstanding as of December 31, 2013	8.7	\$ 15.33	4.30 years
Exercisable as of December 31, 2013	8.1	\$ 14.79	3.94 years
Granted	0.4	\$ 30.23	
Exercised	(4.2)	—	
Forfeited or expired	—	—	
Outstanding as of December 31, 2014	4.9	\$ 17.49	4.19 years
Exercisable as of December 31, 2014	3.9	\$ 15.32	3.08 years

The weighted-average grant-date fair value of options granted during the years ended December 31, 2014, 2013 and 2012 was \$9.51, \$9.76 and \$0.0, respectively. The total fair value of stock options vested during the years ended December 31, 2014, 2013 and 2012 was \$0.0 million, \$0.7 million and \$7.5 million, respectively. The total intrinsic value of stock options exercised during the years ended December 31, 2014, 2013 and 2012 was \$82.3 million, \$58.0 million and \$24.6 million, respectively. The aggregate intrinsic value of stock options outstanding and exercisable was \$80.4 million and \$72.5 million as of December 31, 2014, and \$106.8 million and \$103.8 million as of December 31, 2013, respectively.

A summary of the status of the Company's non-vested stock options as of December 31, 2014, 2013 and 2012, and changes during the period ended December 31, 2014, 2013 and 2012 is presented below:

<u>Non-vested Stock Options:</u>	Options (in millions)	Weighted-Average Grant-Date Fair Value
Non-vested at December 31, 2011	3.4	\$ 2.81
Granted	—	—
Vested	(2.9)	2.58
Forfeited	(0.3)	4.00
Non-vested at December 31, 2012	0.2	\$ 4.34
Granted	0.6	9.76
Vested	(0.2)	3.59
Forfeited	—	—
Non-vested at December 31, 2013	0.6	\$ 9.06
Granted	0.4	9.51
Vested	—	—
Forfeited	—	—
Non-vested at December 31, 2014	1.0	\$ 9.44

As of December 31, 2014, 2013 and 2012, there was \$4.8 million, \$4.2 million and \$0.5 million, respectively, of unrecognized compensation cost related to non-vested stock option compensation arrangements granted under the Prior Plan and the 2011 Plan. This cost is expected to be recognized, on a straight line basis, over a period of approximately two years. Stock option incentive compensation expense recorded was \$3.3 million, \$1.7 million and \$5.5 million for the years ended December 31, 2014, 2013 and 2012, respectively.

NOTE 15. INCOME TAXES

Income before income taxes included the following (dollars in millions):

	Years ended December 31,		
	2014	2013	2012
U.S. income	\$355.1	\$259.0	\$204.1
Foreign income	13.0	7.1	12.1
Total	<u>\$368.1</u>	<u>\$266.1</u>	<u>\$216.2</u>

The provision for income tax expense (benefit) was estimated as follows (dollars in millions):

	Years ended December 31,		
	2014	2013	2012
Estimated current income taxes:			
U.S. federal	\$ 1.6	\$ 0.2	\$ 1.5
Foreign	6.3	1.9	3.9
U.S. state and local	(0.2)	0.6	0.4
Total Current	7.7	2.7	5.8
Deferred income tax expense (credit), net:			
U.S. federal	125.6	87.6	(282.5)
Foreign	(0.3)	0.1	0.1
U.S. state and local	6.5	10.3	(21.4)
Total Deferred	131.8	98.0	(303.8)
Total income tax expense (benefit)	<u>\$139.5</u>	<u>\$100.7</u>	<u>\$(298.0)</u>

Cash paid for income taxes for the years ended December 31, 2014, 2013 and 2012 was \$5.0 million, \$3.8 million and \$10.7 million, respectively.

A reconciliation of the provision for income tax expense (benefit) compared with the amounts at the U.S. federal statutory rate is as follows (dollars in millions):

	Years ended December 31,		
	2014	2013	2012
Tax at U.S. statutory income tax rate	\$128.9	\$ 93.1	\$ 75.7
Foreign rate differential	(2.3)	(0.7)	(2.6)
Non-deductible expenses	3.9	0.8	4.2
Valuation allowance	2.6	1.0	(384.1)
State tax expense	4.0	7.3	5.7
Adjustment to deferred tax expense	2.4	(0.3)	2.2
Other adjustments	(0.0)	(0.5)	0.9
Total income tax expense (benefit)	<u>\$139.5</u>	<u>\$100.7</u>	<u>\$(298.0)</u>

The Company has not recognized any deferred tax liabilities associated with investments and earnings in foreign subsidiaries as they are intended to be permanent in duration. Such amounts may become taxable upon an actual or deemed repatriation in the future; however, at this time, management believes any related unrecognized deferred tax liability is immaterial.

[Table of Contents](#)

Temporary differences and carryforwards that gave rise to deferred tax assets and liabilities included the following (dollars in millions):

	As of December 31, 2014	As of December 31, 2013
Deferred tax assets:		
Inventories	\$ 5.1	\$ 4.6
Warranty accrual	30.5	32.7
Sales allowances and rebates	6.7	7.9
Deferred revenue	25.7	24.0
Post-retirement health care	5.7	—
Intangibles	77.3	83.6
Other accrued liabilities	32.7	27.2
Unrealized loss on interest rate derivatives	5.7	3.7
Operating loss carryforwards	107.8	140.7
Stock based compensation	6.9	12.5
Technology-related investments	6.6	6.8
Loan fees	—	0.9
Other	16.4	10.4
Total Deferred tax assets	327.1	355.0
Valuation allowances	(5.2)	(2.8)
Deferred tax liabilities:		
Property, plant and equipment	(20.2)	(22.0)
Goodwill	(320.8)	(280.3)
Trade name	(90.3)	(60.6)
Product warranty liabilities	(4.3)	(5.6)
Pension	—	(0.5)
Post-retirement health care	—	(0.2)
Other	(3.5)	—
Total Deferred tax liabilities	(439.1)	(369.2)
Net Deferred tax liability	\$ (117.2)	\$ (17.0)

Of the estimated net operating loss carryforwards as of December 31, 2014, approximately 91% relates to U.S. federal net operating loss carryforwards and approximately 9% relates to the U.S. state net operating loss carryforwards. Substantially all U.S. Federal and State operating loss carryforwards will not expire until 2027-2032. As of December 31, 2014, the Company had \$253.3 million of net operating loss carryforwards for U.S. federal income tax purposes. If the Company continues to generate taxable income, it expects to utilize the remaining U.S. federal net operating loss carryforwards as early as the first quarter of 2016.

Management has determined, based on an evaluation of available objective and subjective evidence, that it is more likely than not that certain foreign deferred tax assets will not be realized and therefore continue to offset these deferred tax assets with a valuation allowance of \$5.2 million and \$2.8 million as of December 31, 2014 and 2013, respectively.

In accordance with the FASB's authoritative guidance on accounting for uncertainty in income taxes, the Company has recorded a liability for unrecognized tax benefits related to the 2010 Research & Development Credit. The accounting guidance prescribes a recognition threshold and measurement attributes for the financial statement recognition and measurement of a tax position taken or expected to be taken in a tax return. Management does not anticipate any significant changes in the balance within the coming year. All of the Company's returns (when filed) will remain subject to examination by the various taxing authorities for the duration of the applicable statute of limitations (generally three years from the earlier of the date of filing or the due date of the return). The change in the liability for unrecognized tax benefits are as follows (dollars in millions):

December 31, 2012	\$ —
December 31, 2013	\$ 2.3
Increases in unrecognized tax benefits as a result of current year activity	<u>0.2</u>
December 31, 2014	<u>\$ 2.5</u>

For the years ended December 31, 2014, 2013 and 2012, the Company recognized no interest and penalties in the Consolidated Statements of Comprehensive Income. The Company follows a policy of recording any tax related interest or penalties in Income tax expense.

NOTE 16. OTHER COMPREHENSIVE LOSS

The changes in components of accumulated other comprehensive loss consisted of the following (dollars in millions):

	<u>Before Tax</u>	<u>Tax (Expense) Benefit</u>	<u>After Tax</u>
Balance at December 31, 2011	\$ (33.2)	\$ (23.8)	\$ (57.0)
Foreign currency translation	(0.7)	—	(0.7)
Pension and OPEB liability adjustment	26.7	(11.6)	15.1
Available-for-sale securities	(2.0)	0.7	(1.3)
Net current period other comprehensive loss	<u>\$ 24.0</u>	<u>\$ (10.9)</u>	<u>\$ 13.1</u>
Balance at December 31, 2012	\$ (9.2)	\$ (34.7)	\$ (43.9)
Foreign currency translation	(5.0)	—	(5.0)
Pension and OPEB liability adjustment	46.4	(17.4)	29.0
Available-for-sale securities	(1.9)	0.8	(1.1)
Net current period other comprehensive income	<u>\$ 39.5</u>	<u>\$ (16.6)</u>	<u>\$ 22.9</u>
Balance at December 31, 2013	\$ 30.3	\$ (51.3)	\$ (21.0)
Foreign currency translation	(7.4)	—	(7.4)
Pension and OPEB liability adjustment	(14.6)	5.5	(9.1)
Available-for-sale securities	(3.2)	1.2	(2.0)
Net current period other comprehensive loss	<u>\$ (25.2)</u>	<u>\$ 6.7</u>	<u>\$ (18.5)</u>
Balance at December 31, 2014	\$ 5.1	\$ (44.6)	\$ (39.5)

The following table shows the location in the Consolidated Statements of Comprehensive Income affected by reclassifications from AOCL (dollars in millions):

AOCL Components	<u>For the year ended December 31, 2014</u>	
	<u>Amount reclassified from AOCL</u>	<u>Affected line item in the consolidated statements of comprehensive income</u>
Amortization of defined benefit pension items:		
Prior service cost	\$ 3.2	Cost of sales
	0.3	Selling, general and administrative
	0.1	Engineering – research and development
Actuarial loss	0.7	Cost of sales
	(0.0)	Selling, general and administrative
	(0.0)	Engineering – research and development
Total reclassifications, before tax	4.3	Income before income taxes
Income tax expense	(1.6)	Tax expense
Total reclassifications	<u>\$ 2.7</u>	Net of tax

Prior service cost and actuarial loss are included in the computation of the Company's net periodic benefit cost. Please see NOTE 13 for additional details.

NOTE 17. COMMITMENTS AND CONTINGENCIES***Operating Leases***

The Company leases certain facilities under various operating leases. Rent expense under the non-cancelable operating leases was \$5.4 million, \$5.7 million, and \$5.5 million for the years ended December 31, 2014, 2013 and 2012, respectively. Certain leases contain renewal options.

As of December 31, 2014, future payments under non-cancelable operating leases are as follows over each of the next five years and thereafter (dollars in millions):

2015	\$ 4.6
2016	2.8
2017	1.7
2018	0.8
2019	0.6
Thereafter	2.0
Total	<u>\$12.5</u>

Claims, Disputes, and Litigation

The Company is party to various legal actions and administrative proceedings and subject to various claims arising in the ordinary course of business. These proceedings primarily involve commercial claims, product liability claims, personal injury claims and workers' compensation claims. The Company believes that the ultimate liability, if any, in excess of amounts already provided for in the consolidated financial statements or covered by insurance on the disposition of these matters will not have a material adverse effect on the financial position, results of operations or cash flows of the Company.

NOTE 18. CONCENTRATION OF RISK

As of December 31, 2014 and 2013, the Company employed approximately 2,700 employees, respectively with 90% of those employees in the U.S. Approximately 60% of the Company's U.S. employees were represented by unions and subject to a collective bargaining agreement as of December 31, 2014 and 2013. In addition, many of the hourly employees outside the U.S. are represented by various unions. The Company is currently operating under a collective bargaining agreement with the UAW Local 933 that expires in November 2017.

Three customers accounted for greater than 10% of net sales within the last three years presented.

% of net sales	Years ended December 31,		
	2014	2013	2012
Daimler AG	17%	17%	13%
Navistar, Inc.	10%	10%	11%
Oshkosh Corporation	4%	8%	11%

No other customers accounted for more than 10% of net sales of the Company during the years ended December 31, 2014, 2013 or 2012.

Three customers accounted for greater than 10% of outstanding accounts receivable within the last two years presented.

% of accounts receivable	As of	As of
	December 31, 2014	December 31, 2013
Daimler AG	15%	15%
Navistar, Inc.	12%	10%
AB Volvo.	8%	11%

No other customers accounted for more than 10% of the outstanding accounts receivable as of December 31, 2014 or December 31, 2013.

[Table of Contents](#)

One supplier accounted for greater than 10% of materials purchased for the periods presented:

% of material purchased	Years ended December 31,		
	2014	2013	2012
Linamar Corporation Inc.	10%	13%	13%

No other supplier accounted for more than 10% of materials purchased during the years ended December 31, 2014, 2013 or 2012.

NOTE 19. CERTAIN RELATIONSHIPS AND RELATED PARTY TRANSACTIONS

Investment funds affiliated with the Sponsors sold their common stock through a series of public offerings from March 2012 through September 2014. As of December 31, 2014, investment funds affiliated with the Sponsors no longer own any shares of the Company's outstanding common stock. Pursuant to an amended and restated stockholders agreement, a majority of the Board of Directors had previously been designated by the Sponsors; however, as a result of their no longer owning any shares of the Company's common stock, the Sponsors no longer have the right to designate members of the Board of Directors.

Senior Notes Held by Executive Officers

As of December 31, 2014, Lawrence E. Dewey, our Chairman, President and Chief Executive Officer, and David S. Graziosi, our Executive Vice President, Chief Financial Officer and Treasurer, held approximately \$100,000 and \$450,000, respectively, in aggregate principal amount of the 7.125% Senior Notes.

Repurchase of Common Stock held by Sponsors

During 2014, the Company completed four secondary public offerings in September, June, April and February of 5,392,499, 40,250,000, 25,000,000, and 28,750,000 shares of its common stock held by investment funds affiliated with the Sponsors at public offering prices, less underwriting discounts and commissions, of \$30.46, \$29.95, \$29.78 and \$29.17 per share, respectively. In connection with certain of the offerings, the Company repurchased from the underwriters 5,000,000 shares in June 2014 and 3,428,179 shares in February 2014 at the prices paid by the underwriters and subsequently retired those shares.

During 2013, the Company completed three secondary public offerings in August, November and December of 23,805,000, 15,000,000 and 12,500,000 shares of its common stock held by investment funds affiliated with the Sponsors at a public offering price, less underwriting discounts and commissions, of \$21.18, \$23.10 and \$25.56 per share, respectively. In connection with the offering in August, the Company repurchased from the underwriters 4,700,000 shares of the 23,805,000 shares at the price paid by the underwriters and subsequently retired those shares.

NOTE 20. COMMON STOCK

The Company's current stock repurchase program was announced on October 30, 2014. The Board authorized management to repurchase up to \$500.0 million of its common stock on the open market or through privately negotiated transactions through December 31, 2016. The timing and amount of stock purchases are subject to market conditions and corporate needs. This stock repurchase program may be extended, modified, suspended or discontinued at any time at the Company's discretion. As of December 31, 2014, \$500.0 million remained available for stock repurchases under the repurchase program.

NOTE 21. EARNINGS PER SHARE

The Company presents both basic and diluted earnings per share (“EPS”) amounts. Basic EPS is calculated by dividing net income by the weighted average number of common shares outstanding during the reporting period. Diluted EPS is calculated by dividing net income by the weighted average number of common shares and common equivalent shares outstanding during the reporting period that are calculated using the treasury stock method for stock-based awards. The treasury stock method assumes that the Company uses the proceeds from the exercise of awards to repurchase common stock at the average market price during the period. The assumed proceeds under the treasury stock method include the purchase price that the grantee will pay in the future, compensation cost for future service that the Company has not yet recognized and any tax benefits that would be credited to additional paid-in-capital when the award generates a tax deduction. If there would be a shortfall resulting in a charge to additional paid-in-capital, such an amount would be a reduction of the proceeds to the extent of the gains. The diluted weighted-average common shares outstanding exclude the anti-dilutive effect of certain stock options since such options had an exercise price in excess of the monthly average market value of our common stock. As of December 31, 2014, there were no outstanding anti-dilutive stock options.

The following table reconciles the numerators and denominators used to calculate basic EPS and diluted EPS (in millions, except per share data):

	Years ended December 31,		
	2014	2013	2012
Net income	<u>\$228.6</u>	<u>\$165.4</u>	<u>\$514.2</u>
Weighted average shares of common stock outstanding	179.8	184.5	182.0
Dilutive effect stock-based awards	2.5	3.4	4.2
Diluted weighted average shares of common stock outstanding	<u>182.3</u>	<u>187.9</u>	<u>186.2</u>
Basic earnings per share attributable to common stockholders	<u>\$ 1.27</u>	<u>\$ 0.90</u>	<u>\$ 2.83</u>
Diluted earnings per share attributable to common stockholders	<u>\$ 1.25</u>	<u>\$ 0.88</u>	<u>\$ 2.76</u>

NOTE 22. GEOGRAPHIC INFORMATION

The Company had the following net sales by country as follows (dollars in millions):

	Years ended December 31,		
	2014	2013	2012
United States	<u>\$1,578.0</u>	<u>\$1,354.3</u>	<u>\$1,509.6</u>
China	128.7	141.0	136.4
Canada	85.1	88.6	123.0
Japan	45.8	37.0	52.0
Germany	38.1	53.9	39.1
United Kingdom	36.8	42.5	74.1
Other	214.9	209.5	207.6
Total	<u>\$2,127.4</u>	<u>\$1,926.8</u>	<u>\$2,141.8</u>

The Company had net long-lived assets by country as follows (dollars in millions):

	Years ended December 31,		
	2014	2013	2012
United States	<u>\$442.6</u>	<u>\$478.7</u>	<u>\$493.6</u>
India	51.5	59.9	76.8
Hungary	15.1	18.1	18.4
Others	5.4	6.7	7.4
Total	<u>\$514.6</u>	<u>\$563.4</u>	<u>\$596.2</u>

NOTE 23. QUARTERLY FINANCIAL INFORMATION

The following is a summary of the unaudited quarterly results of operations. The Company believes that all adjustments considered necessary for a fair presentation in accordance with GAAP have been included (unaudited, in millions, except per share data).

	Quarters ended,			
	March 31	June 30	September 30	December 31
2014				
Net sales	\$ 493.6	\$536.1	\$ 553.3	\$ 544.4
Gross profit	222.5	238.5	259.3	255.6
Operating income	114.8	132.2	147.3	117.8
Income before income taxes	79.3	94.7	116.3	77.8
Net income	52.1	57.2	68.8	50.5
Basic earnings per share	\$ 0.29	\$ 0.32	\$ 0.38	\$ 0.28
Diluted earnings per share	\$ 0.28	\$ 0.31	\$ 0.38	\$ 0.28
2013				
Net sales	\$ 457.4	\$512.1	\$ 466.3	\$ 491.0
Gross profit	198.3	226.1	206.1	211.4
Operating income	81.4	117.7	111.2	99.6
Income before income taxes	44.4	81.8	72.4	67.5
Net income	27.5	50.5	44.5	42.9
Basic earnings per share	\$ 0.15	\$ 0.27	\$ 0.24	\$ 0.24
Diluted earnings per share	\$ 0.15	\$ 0.26	\$ 0.24	\$ 0.23

Allison Transmission Holdings, Inc.
Schedule I—Parent Company only Balance Sheets
(dollars in millions)

	December 31, 2014	December 31, 2013
ASSETS		
Current Assets:		
Cash	\$ —	\$ —
Total Current Assets	—	—
Investments in and advances to subsidiaries	1,397.8	1,438.8
TOTAL ASSETS	<u>\$ 1,397.8</u>	<u>\$ 1,438.8</u>
LIABILITIES AND STOCKHOLDERS' EQUITY		
Current Liabilities:		
Accounts payable	\$ —	\$ —
Total Current Liabilities	—	—
Capital stock	1.8	1.8
Additional paid-in-capital	1,651.0	1,631.8
Treasury stock	—	—
Accumulated deficit	(215.5)	(173.8)
Accumulated other comprehensive loss, net of tax	(39.5)	(21.0)
TOTAL LIABILITIES AND STOCKHOLDERS' EQUITY	<u>\$ 1,397.8</u>	<u>\$ 1,438.8</u>

The accompanying note is an integral part of the Parent Company only financial statements.

Allison Transmission Holdings, Inc.
Schedule I—Parent Company only Statements of Comprehensive Income
(dollars in millions)

	Years ended December 31,		
	2014	2013	2012
Net sales	\$ —	\$ —	\$ —
General and administrative fees	—	—	—
Total operating income	—	—	—
Other income:			
Equity earnings of consolidated subsidiary	228.6	165.4	514.2
Income before income taxes	228.6	165.4	514.2
Income tax expense	—	—	—
Net income	<u>228.6</u>	<u>\$165.4</u>	<u>\$514.2</u>
Comprehensive income	<u>228.6</u>	<u>\$165.4</u>	<u>\$514.2</u>

The accompanying note is an integral part of the Parent Company only financial statements.

Allison Transmission Holdings, Inc.
Schedule I—Parent Company only Statements of Cash Flows
(dollars in millions)

	Years ended December 31,		
	2014	2013	2012
CASH FLOWS FROM OPERATING ACTIVITIES:			
Net income	\$ 228.6	\$ 165.4	\$ 514.2
Deduct items included in net income not providing cash:			
Equity in earnings in consolidated subsidiary	(228.6)	(165.4)	(514.2)
Net cash provided by operating activities	—	—	—
CASH FLOWS FROM INVESTING ACTIVITIES:			
Investments in subsidiaries	(59.6)	(46.3)	(29.0)
Dividends	91.6	77.1	32.8
Net cash provided by investing activities	32.0	30.8	3.8
CASH FLOWS FROM FINANCING ACTIVITIES:			
Capital contributions	59.6	46.3	29.0
Dividends	(91.6)	(77.1)	(32.8)
Net cash used in financing activities	(32.0)	(30.8)	(3.8)
Net increase (decrease) during period	—	—	—
Cash and cash equivalents at beginning of period	—	—	—
Cash and cash equivalents at end of period	\$ —	\$ —	\$ —

The accompanying note is an integral part of the Parent Company only financial statements.

Allison Transmission Holdings, Inc.
Schedule I—Parent Company only Footnote

NOTE 1—BASIS OF PRESENTATION

Allison Transmission Holdings, Inc. (the “Parent Company”) is a holding company that conducts all of its business operations through its subsidiaries. There are restrictions on the Parent Company’s ability to obtain funds from its subsidiaries through dividends (refer to NOTE 7 of the Consolidated Financial Statements). The entire amount of our consolidated net assets was subject to restrictions on payment of dividends at the end of December 31, 2014, 2013 and 2012. Accordingly, these financial statements have been presented on a “parent-only” basis. Under a parent-only presentation, the Parent Company’s investments in its consolidated subsidiaries are presented under the equity method of accounting. These parent-only financial statements should be read in conjunction with Allison Transmission Holdings, Inc.’s audited Consolidated Financial Statements included elsewhere herein.

ITEM 9. Changes in and Disagreements with Accountants on Accounting and Financial Disclosure

None.

ITEM 9A. Controls and Procedures

Evaluation of Disclosure Controls and Procedures

Our management, with the participation of our Chief Executive Officer and Chief Financial Officer, evaluated the effectiveness of our disclosure controls and procedures (as defined in Rules 13a-15(e) and 15d-15(e) under the Exchange Act), as of December 31, 2014. In designing and evaluating the disclosure controls and procedures, management recognized that any controls and procedures, no matter how well designed and operated, can provide only reasonable assurance of achieving the desired control objectives. In addition, the design of disclosure controls and procedures must reflect the fact that there are resource constraints and that management is required to apply its judgment in evaluating the benefits of possible controls and procedures relative to their costs.

Based on the evaluation, our Chief Executive Officer and Chief Financial Officer concluded that our disclosure controls and procedures as of December 31, 2014, the end of the period covered by this Annual Report on Form 10-K, were effective to provide reasonable assurance that information we are required to disclose in reports that we file or submit under the Exchange Act is recorded, processed, summarized and reported within the time periods specified in the Securities and Exchange Commission rules and forms, and that such information is accumulated and communicated to our management, including our Chief Executive Officer and Chief Financial Officer, as appropriate, to allow timely decisions regarding required disclosure.

Management's Report on Internal Control Over Financial Reporting

Our management is responsible for establishing and maintaining adequate internal control over financial reporting (as defined in Rules 13a-15(f) and 15d-15(f) under the Exchange Act). Our internal control over financial reporting is a process designed to provide reasonable assurance regarding the reliability of financial reporting and the preparation of financial statements for external purposes in accordance with generally accepted accounting principles.

Because of its inherent limitations, internal control over financial reporting may not prevent or detect misstatements. Also, projections of any evaluation of effectiveness to future periods are subject to the risk that controls may become inadequate because of changes in conditions, or that the degree of compliance with the policies or procedures may deteriorate.

Under the supervision and with the participation of our management, including our Chief Executive Officer and Chief Financial Officer, we conducted an assessment of the effectiveness of our internal control over financial reporting as of December 31, 2014. In making this assessment, our management used the criteria set forth by the Committee of Sponsoring Organizations of the Treadway Commission in *Internal Control—Integrated Framework* (2013). Based on this assessment, management concluded that our internal control over financial reporting was effective as of December 31, 2014. PricewaterhouseCoopers LLP, our independent registered public accounting firm, has audited the effectiveness of our internal control over financial reporting as of December 31, 2014. Their report is included in Part II, Item 8, "Financial Statements and Supplementary Data" in this Annual Report on Form 10-K.

Changes in Internal Control over Financial Reporting

There were no changes in our internal control over financial reporting (as defined in Rules 13a-15(f) and 15d-15(f) under the Exchange Act) during the quarter ended December 31, 2014 that have materially affected, or are reasonably likely to materially affect, our internal control over financial reporting.

ITEM 9B. Other Information

None.

PART III.

ITEM 10. Directors, Executive Officers and Corporate Governance

The information required by this Item concerning our executive officers, directors and nominees for director, Audit Committee members and financial expert(s) and disclosure of delinquent filers under Section 16(a) of the Exchange Act is incorporated herein by reference from our definitive Proxy Statement for our 2015 annual meeting of stockholders which will be filed with the SEC pursuant to Regulation 14A within 120 days after the end of our last fiscal year.

Code of Business Conduct

We have adopted the Allison Code of Business Conduct that applies to all of our directors and officers and other employees, including our principal executive officer, principal financial officer and principal accounting officer. This code is publicly available through the Investor Relations section of our website at www.allisontransmission.com. We will post on the Investor Relations section of our website any amendment to the code of business conduct, or any grant of a waiver from a provision of the code of business conduct.

ITEM 11. Executive Compensation

The information required by this Item concerning remuneration of our executive officers and directors, material transactions involving such executive officers and directors and Compensation Committee interlocks, as well as the Compensation Committee Report, are incorporated herein by reference to our definitive Proxy Statement for our 2015 annual meeting of stockholders which will be filed with the SEC pursuant to Regulation 14A within 120 days after the end of our last fiscal year.

ITEM 12. Security Ownership of Certain Beneficial Owners and Management and Related Stockholder Matters

The information required by this Item concerning the stock ownership of management, five percent beneficial owners and securities authorized for issuance under equity compensation plans is incorporated herein by reference to our definitive Proxy Statement for our 2015 annual meeting of stockholders which will be filed with the SEC pursuant to Regulation 14A within 120 days after the end of our last fiscal year.

ITEM 13. Certain Relationships and Related Transactions, and Director Independence

The information required by this Item concerning certain relationships and related person transactions, and director independence is incorporated herein by reference to our definitive Proxy Statement for our 2015 annual meeting of stockholders which will be filed with the SEC pursuant to Regulation 14A within 120 days after the end of our last fiscal year.

ITEM 14. Principal Accounting Fees and Services

The information required by this Item concerning the fees and services of our independent registered public accounting firm and our Audit Committee actions with respect thereto is incorporated herein by reference to our definitive Proxy Statement for our 2015 annual meeting of stockholders which will be filed with the SEC pursuant to Regulation 14A within 120 days after the end of our last fiscal year.

PART IV.

ITEM 15. Exhibits, Financial Statement Schedules

(a)(1) Financial Statements.

The response to this item is included in Part II, Item 8, of this Annual Report on Form 10-K.

(a)(2) Financial Statement Schedules.

Schedule I is included in Part II, Item 8, of this Annual Report on Form 10-K. All other schedules have been omitted because they are not required or because the information required is included in the consolidated financial statements and notes thereto.

(a)(3) Exhibits

See the response to Item 15(b) below.

(b) Exhibits

The following exhibits are filed as part of, or are incorporated by reference into, this Annual Report on Form 10-K:

<u>Exhibit No.</u>	<u>DESCRIPTION OF EXHIBIT</u>
3.1	Amended and Restated Certificate of Incorporation of Allison Transmission Holdings, Inc. (incorporated by reference to Exhibit 3.1 to the Registrant's Quarterly Report on Form 10-Q for the quarter ended March 31, 2012 filed on April 26, 2012)
3.2	Amended and Restated Bylaws of Allison Transmission Holdings, Inc. (incorporated by reference to Exhibit 3.2 to the Registrant's Quarterly Report on Form 10-Q for the quarter ended March 31, 2012 filed on April 26, 2012)
4.1	Form of Stock Certificate (incorporated by reference to Exhibit 4.1 to Amendment No. 3 to the Registrant's Registration Statement on Form S-1 filed June 16, 2011)
4.2	Indenture governing the 7.125% Senior Notes due 2019, among Allison Transmission, Inc. as Issuer, the Guarantors named therein, and Wells Fargo Bank, National Association, as trustee, dated May 6, 2011 (incorporated by reference to Exhibit 4.6 to Amendment No. 2 to the Registrant's Registration Statement on Form S-1 filed May 16, 2011)
4.3	Form of 7.125% Senior Note due 2019 (included in Exhibit 4.6)
10.1	Credit Agreement among Allison Transmission Holdings, Inc., Allison Transmission, Inc., as Borrower, the Several Lenders from time to time parties thereto, Citicorp North America, Inc., as Administrative Agent, Lehman Brothers Commercial Bank and Merrill Lynch, Pierce, Fenner & Smith Incorporated, as Syndication Agents, Sumitomo Mitsui Banking Corporation, as Documentation Agent and Co-Arranger and Citigroup Global Markets Inc., Lehman Brothers Inc. and Merrill Lynch & Co., Merrill Lynch, Pierce, Fenner & Smith Incorporated, As Joint Lead Arrangers And Joint Bookrunners, dated as of August 7, 2007 (incorporated by reference to Exhibit 10.1 to Amendment No. 1 to the Registrant's Registration Statement on Form S-1 filed April 26, 2011)
10.2	First Amendment to the Credit Agreement among Allison Transmission Holdings, Inc., Allison Transmission, Inc., as Borrower, the Several Lenders from time to time parties thereto, Citicorp North America, Inc., as Administrative Agent, Lehman Brothers Commercial Bank and Merrill Lynch, Pierce, Fenner & Smith Incorporated, as Syndication Agents, Sumitomo Mitsui Banking Corporation, as Documentation Agent and Co-Arranger and Citigroup Global Markets Inc., Lehman Brothers Inc. and Merrill Lynch & Co., Merrill Lynch, Pierce, Fenner & Smith Incorporated, As Joint Lead Arrangers And Joint Bookrunners, dated as of November 21, 2008 (incorporated by reference to Exhibit 10.2 to the Registrant's Registration Statement on Form S-1 filed March 18, 2011)
10.3	Guarantee And Collateral Agreement made by Allison Transmission Holdings, Inc. Allison Transmission, Inc. as Borrower, and the Subsidiary Guarantors party hereto in favor of Citicorp North America, Inc., as Administrative Agent, dated as of August 7, 2007 (incorporated by reference to Exhibit 10.3 to the Registrant's Registration Statement on Form S-1 filed March 18, 2011)

Table of Contents

- 10.4 Trademark Security Agreement made by Allison Transmission, Inc. in favor of Citicorp North America, Inc., as Administrative Agent, dated as of August 7, 2007 (incorporated by reference to Exhibit 10.4 to the Registrant's Registration Statement on Form S-1 filed March 18, 2011)
- 10.5 Copyright Security Agreement made by Allison Transmission, Inc. in favor of Citicorp North America, Inc., as Administrative Agent, dated as of August 7, 2007 (incorporated by reference to Exhibit 10.5 to Amendment No. 2 to the Registrant's Registration Statement on Form S-1 filed May 16, 2011)
- 10.6 Amended and Restated Stockholders Agreement (incorporated by reference to Exhibit 10.6 to the Registrant's Quarterly Report on Form 10-Q for the quarter ended March 31, 2012 filed on April 26, 2012)
- 10.7* Form of Allison Transmission Holdings, Inc. Indemnification Agreement (incorporated by reference to Exhibit 10.9 to Amendment No. 2 to the Registrant's Registration Statement on Form S-1 filed May 16, 2011)
- 10.8* Allison Transmission Holdings, Inc. 2011 Equity Incentive Award Plan (incorporated by reference to Exhibit 10.10 to Amendment No. 3 to the Registrant's Registration Statement on Form S-1 filed June 16, 2011)
- 10.9* Form of 2011 Equity Incentive Award Plan Restricted Stock Agreement (incorporated by reference to Exhibit 10.11 to Amendment No. 3 to the Registrant's Registration Statement on Form S-1 filed June 16, 2011)
- 10.10* Form of 2011 Equity Incentive Award Plan Restricted Stock Unit Agreement (incorporated by reference to Exhibit 10.12 to Amendment No. 3 to the Registrant's Registration Statement on Form S-1 filed June 16, 2011)
- 10.11* Form of 2011 Equity Incentive Award Plan Stock Option Agreement (incorporated by reference to Exhibit 10.13 to Amendment No. 3 to the Registrant's Registration Statement on Form S-1 filed June 16, 2011)
- 10.12* Equity Incentive Plan of Allison Transmission Holdings, Inc. (incorporated by reference to Exhibit 10.14 to Amendment No. 2 to the Registrant's Registration Statement on Form S-1 filed May 16, 2011)
- 10.13* Form of Employee Stock Option Agreement under Equity Incentive Plan of Allison Transmission Holdings, Inc. (incorporated by reference to Exhibit 10.15 to Amendment No. 2 to the Registrant's Registration Statement on Form S-1 filed May 16, 2011)
- 10.14* Form of Independent Director Stock Option Agreement under Equity Incentive Plan of Allison Transmission Holdings, Inc. (incorporated by reference to Exhibit 10.16 to Amendment No. 2 to the Registrant's Registration Statement on Form S-1 filed May 16, 2011)
- 10.15 Second Amendment to the Credit Agreement among Allison Transmission Holdings, Inc., Allison Transmission, Inc., as Borrower, the several banks and other financial institutions or entities from time to time parties thereto as Lenders, Citicorp North America, Inc., as Administrative Agent and Collateral Agent, Lehman Brothers Commercial Bank and Merrill Lynch, Pierce, Fenner & Smith Incorporated, as Syndication Agents, Sumitomo Mitsui Banking Corporation, as Documentation Agent and Co-Arranger, and Citigroup Global Markets Inc., Lehman Brothers Inc., and Merrill Lynch & Co., Merrill Lynch, Pierce, Fenner & Smith Incorporated, as Joint Lead Arrangers and Joint Bookrunners, dated as of May 13, 2011 (incorporated by reference to Exhibit 10.17 to Amendment No. 3 to the Registrant's Registration Statement on Form S-1 filed June 16, 2011)
- 10.16 Third Amendment to the Credit Agreement among Allison Transmission Holdings, Inc., Allison Transmission, Inc., as Borrower, the several banks and other financial institutions or entities from time to time parties thereto as Lenders, Citicorp North America, Inc., as Administrative Agent and Collateral Agent and the other agents and arrangers party thereto, dated as of March 9, 2012 (incorporated by reference to Exhibit 10.19 to Amendment No. 8 to the Registrant's Registration Statement on Form S-1 filed March 12, 2012)
- 10.17* Incentive Plan of Allison Transmission Holdings, Inc. (incorporated by reference to Exhibit 10.20 to the Registrant's Quarterly Report on Form 10-Q for the quarter ended June 30, 2012 filed on July 31, 2012)
- 10.18* Deferred Compensation Plan of Allison Transmission Inc. (incorporated by reference to Exhibit 10.21 to the Registrant's Quarterly Report on Form 10-Q for the quarter ended June 30, 2012 filed on July 31, 2012)
- 10.19 Amendment No. 4 to the Credit Agreement, dated as of August 23, 2012, among Allison Transmission Holdings, Inc., Allison Transmission, Inc., as Borrower, the several banks and other financial institutions or entities from time to time parties thereto as Lenders, Citicorp North America, Inc., as Administrative Agent and the other agents and arrangers party thereto (incorporated by reference to Exhibit 10.1 to the Registrant's Current Report on Form 8-K filed August 23, 2012)

Table of Contents

- 10.20 Amendment No. 5 to the Credit Agreement, dated as of October 4, 2012, among Allison Transmission Holdings, Inc., Allison Transmission, Inc., as Borrower, the several banks and other financial institutions or entities from time to time parties thereto as Lenders, Citicorp North America, Inc., as Administrative Agent and the other agents and arrangers party thereto (incorporated by reference to Exhibit 10.1 to the Registrant's Current Report on Form 8-K filed October 4, 2012)
- 10.21* Non-Employee Director Deferred Compensation Plan of Allison Transmission Holdings, Inc. (incorporated by reference to Exhibit 10.23 to the Registrant's Annual Report on Form 10-K for the year ended December 31, 2012 filed on February 28, 2013)
- 10.22* Form Amendment to Stock Option Agreement under Equity Incentive Plan of Allison Transmission Holdings, Inc. (incorporated by reference to Exhibit 10.24 to the Registrant's Annual Report on Form 10-K for the year ended December 31, 2012 filed on February 28, 2013)
- 10.23 Amendment No. 6 to the Credit Agreement, dated as of February 6, 2013, among Allison Transmission Holdings, Inc., Allison Transmission, Inc., as Borrower, the several banks and other financial institutions or entities from time to time parties thereto as Lenders, Citicorp North America, Inc., as Administrative Agent and the other agents and arrangers party thereto (incorporated by reference to Exhibit 10.1 to the Registrant's Current Report on Form 8-K filed February 6, 2013)
- 10.24 Amendment No. 7 to the Credit Agreement, dated as of February 6, 2013 among Allison Transmission Holdings, Inc., Allison Transmission, Inc., as Borrower, the several banks and other financial institutions or entities from time to time parties thereto as Lenders, Citicorp North America, Inc., as Administrative Agent and the other agents and arrangers party thereto (incorporated by reference to Exhibit 10.2 to the Registrant's Current Report on Form 8-K filed February 6, 2013)
- 10.25* Form Amendment to Stock Option Agreement under the Allison Transmission Holdings, Inc. 2011 Equity Incentive Award Plan and Equity Incentive Plan of Allison Transmission Holdings, Inc. (incorporated by reference to Exhibit 10.27 to the Registrant's Quarterly Report on Form 10-Q for the quarter ended June 30, 2013 filed on July 30, 2013)
- 10.26 First Amendment to the Stockholders Agreement dated as of May 8, 2013 (incorporated by reference to Exhibit 10.28 to the Registrant's Quarterly Report on Form 10-Q for the quarter ended June 30, 2013 filed on July 30, 2013)
- 10.27* Form of 2011 Equity Incentive Award Plan Stock Option Agreement (incorporated by reference to Exhibit 10.29 to the Registrant's Quarterly Report on Form 10-Q for the quarter ended September 30, 2013 filed on October 29, 2013)
- 10.28 Amendment No. 8 to the Credit Agreement, dated as of August 26, 2013, among Allison Transmission Holdings, Inc., Allison Transmission, Inc., as Borrower, the several banks and other financial institutions or entities from time to time parties thereto as Lenders, Citicorp North America, Inc., as Administrative Agent and the other agents and arrangers party thereto (incorporated by reference to Exhibit 10.1 to the Registrant's Current Report on Form 8-K filed August 26, 2013)
- 10.29 Amendment No. 9 to the Credit Agreement, dated as of December 31, 2013, among Allison Transmission Holdings, Inc., Allison Transmission, Inc., as Borrower, the several banks and other financial institutions or entities from time to time parties thereto as Lenders, Citicorp North America, Inc., as Administrative Agent and the other agents and arrangers party thereto (incorporated by reference to Exhibit 10.1 to the Registrant's Current Report on Form 8-K filed December 31, 2013)
- 10.30* Form of Change in Control Severance Agreement (incorporated by reference to Exhibit 10.34 to the Registrant's Annual Report on Form 10-K for the year ended December 31, 2013 filed on February 24, 2014)
- 10.31 Consent Agreement to the Credit Agreement, dated as of March 12, 2014, among Allison Transmission Holdings, Inc., Allison Transmission, Inc., as Borrower, the several banks and other financial institutions or entities from time to time parties thereto as Lenders, Citicorp North America, Inc., as Administrative Agent, and the other agents and arrangers party thereto (incorporated by reference to Exhibit 10.1 to the Registrant's Current Report on Form 8-K filed March 14, 2014)
- 10.32 Amendment No. 10 to the Credit Agreement, dated as of April 14, 2014, among Allison Transmission Holdings, Inc., Allison Transmission, Inc., as Borrower, the several banks and other financial institutions or entities from time to time parties thereto as Lenders, Citicorp North America, Inc., as Administrative Agent and the other agents and arrangers party thereto (incorporated by reference to Exhibit 10.1 to the Registrant's Current Report on Form 8-K filed April 15, 2014)

Table of Contents

10.33*	Employment Agreement, between Allison Transmission, Inc. and Lawrence E. Dewey, dated as of April 15, 2014 (incorporated by reference to Exhibit 10.2 to the Registrant's Current Report on Form 8-K filed April 15, 2014)
10.34*	Employment Agreement, between Allison Transmission, Inc. and David S. Graziosi, dated as of April 15, 2014 (incorporated by reference to Exhibit 10.3 to the Registrant's Current Report on Form 8-K filed April 15, 2014)
10.35*	Amended and Restated Non-Employee Director Compensation Policy (incorporated by reference to Exhibit 10.39 to the Registrant's Quarterly Report on Form 10-Q for the quarter ended June 30, 2014 filed July 25, 2014)
10.36*	Form of 2011 Equity Incentive Award Plan Restricted Stock Unit Agreement for Non-Employee Directors for 2014 Compensation (incorporated by reference to Exhibit 10.40 to the Registrant's Quarterly Report on Form 10-Q for the quarter ended June 30, 2014 filed July 25, 2014)
14.1	Code of Business Conduct, adopted by the Board of Directors on October 30, 2014 (filed herewith)
21.1	List of Subsidiaries of Allison Transmission Holdings, Inc. (filed herewith)
23.1	Consent of PricewaterhouseCoopers LLP (filed herewith)
31.1	Certification pursuant to Rule 13a-14(a)/15d-14(a) of the Securities Exchange Act of 1934 of the Chief Executive Officer, as adopted pursuant to Section 302 of the Sarbanes-Oxley Act of 2002 (filed herewith)
31.2	Certification pursuant to Rule 13a-14(a)/15d-14(a) of the Securities Exchange Act of 1934 of the Chief Financial Officer, as adopted pursuant to Section 302 of the Sarbanes-Oxley Act of 2002 (filed herewith)
32.1	Certification pursuant to 18 U.S.C. Section 1350, as adopted pursuant to Section 906 of the Sarbanes-Oxley Act of 2002 (filed herewith)
101.INS	XBRL Instance Document
101.SCH	XBRL Taxonomy Extension Schema Document
101.CAL	XBRL Taxonomy Extension Calculation Linkbase Document
101.DEF	XBRL Taxonomy Extension Definition Linkbase Document
101.LAB	XBRL Taxonomy Extension Label Linkbase Document
101.PRE	XBRL Taxonomy Extension Presentation Linkbase Document

* Indicates a management contract or compensatory plan or arrangement

SIGNATURES

Pursuant to the requirements of Section 13 or 15(d) of the Securities Exchange Act of 1934, the registrant has duly caused this report to be signed on its behalf by the undersigned, thereunto duly authorized.

Allison Transmission Holdings, Inc.
(Registrant)

Date: February 20, 2015

By: /s/ Lawrence E. Dewey
Lawrence E. Dewey
Chairman of the Board, President and Chief Executive Officer (Principal Executive Officer)

Pursuant to the requirements of the Securities Exchange Act of 1934, this report has been signed below by the following persons on behalf of the registrant and in the capacities and on the dates indicated.

<u>SIGNATURES</u>	<u>CAPACITY</u>	<u>DATE</u>
<u>/s/ Lawrence E. Dewey</u> Lawrence E. Dewey	Chairman of the Board, President and Chief Executive Officer (Principal Executive Officer)	February 20, 2015
<u>/s/ David S. Graziosi</u> David S. Graziosi	Executive Vice President, Chief Financial Officer and Treasurer (Principal Financial Officer and Principal Accounting Officer)	February 20, 2015
<u>/s/ Brian A. Bernasek</u> Brian A. Bernasek	Director	February 20, 2015
<u>/s/ David Denison</u> David Denison	Director	February 20, 2015
<u>/s/ David Everitt</u> David Everitt	Director	February 20, 2015
<u>/s/ Gregory S. Ledford</u> Gregory S. Ledford	Director	February 20, 2015
<u>/s/ Kosty Gilis</u> Kosty Gilis	Director	February 20, 2015
<u>/s/ Thomas W. Rabaut</u> Thomas W. Rabaut	Director	February 20, 2015
<u>/s/ Francis Raborn</u> Francis Raborn	Director	February 20, 2015
<u>/s/ Richard V. Reynolds</u> Richard V. Reynolds	Director	February 20, 2015



CODE OF BUSINESS CONDUCT

DRIVING INTEGRITY WORLDWIDE

www.allisontransmission.com

TABLE OF CONTENTS

Allison Transmission Leadership Message	1
Introduction	3
<hr/>	
Who Must Follow the Allison Code of Business Conduct, The Employee Code	
Personal Integrity	5
<hr/>	
Understanding the Rules	6
Acting With Integrity When the Rules Seem Unclear	6
Integrity In The Workplace	7
<hr/>	
Fair Treatment and Respect	
Equal Employment Opportunity	
Health and Safety	8
Conflicts of Interest	9
Corporate Opportunities	
Interest in Personal Relationships	
Allison Conflict of Interest Questionnaire	13
Use of Allison Property	19
Litigation and Investigations	
Integrity In The Marketplace	21
<hr/>	
Fair Competition	
Gifts, Entertainment and Gratuities	
Relations With Competitors	
Relations with Dealers, Distributors and Resellers	22
International Consideration	
Insider Trading	23

Integrity In Our Societies And Communities 25

Conflicts with Laws
Improper Gifts and Payments

Integrity Toward The Environment 29

Allison Transmission Environmental Principles
Compliance With the Law 30

Conclusions 31

Resources and Contact Information 33

If you have any questions about any of the Allison policies or the content of this *Allison Code of Business Conduct* document, contact the Human Resources or Legal departments.



ALLISON TRANSMISSION LEADERSHIP MESSAGE

Allison Team Members,

As a global business, our reputation is an extremely important asset. At Allison, we realize our reputation is based on everything that we do and all of us have a shared responsibility to maintain the highest standard of integrity.

Our reputation and our integrity determine how we are viewed by our most valued stakeholders — our workforce, customers, shareholders, business partners, government agencies and the communities where we live and work. They also shape the way we feel about ourselves and serve as a reminder of the commitment we've made to those who have entrusted us to conduct all of our business dealings at the highest level of integrity.

We also fully realize our reputation must go beyond the quality of our products and services. It must be built upon the conduct of each Allison employee and those who represent us — not only in words, but more importantly, in our deeds. Our *Allison Code of Business Conduct – "Driving Integrity Worldwide"* should be evident on a day-to-day basis in the way we perform our duties and how we interact with others. For Allison and its global operations, it clearly is the only acceptable way to do business.

To make sure we're conducting our business with integrity every day, each of us at Allison needs to be constantly aware of the situations that challenge us to exercise good judgment. If you are faced with an ethical dilemma, it is important that you quickly raise this matter with your leadership, a member of Allison's management team, our Chief Compliance Officer or via the Allison Care Line. It is of the utmost importance that we all ensure we are acting lawfully and responsibly. Each of us needs a clear understanding of Allison's core values and the laws that are pertinent to the work we do and the decisions we make.

**"...To conduct all of our business
dealings at the highest level of integrity."**

In this *Allison Code of Business Conduct* document, you will find guidelines for employee conduct that reflect Allison's core values and the principles of the UN Global Compact and the UN Universal Declaration of Human Rights. Of course, it is not possible to provide specific guidance for every situation an individual may encounter. Allison entrusts its employees to embrace its values and policies, carefully assessing each situation and seeking guidance from our leaders when unsure about the appropriate course of action.

Thank you in advance for doing your part to make sure Allison will continue to be viewed as a global symbol of excellence.

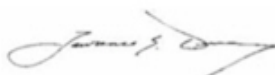

Lawrence E. Dewey

*Chairman, President and Chief Executive Officer
Allison Transmission, Inc.*



INTRODUCTION

Who Must Follow the Allison Code of Business Conduct?

- This Allison Code of Business Conduct – “Driving Integrity Worldwide” has been adopted by the Board of Directors and applies to all Allison salaried employees (including directors and officers) of Allison Transmission, Inc., its holding company and its subsidiaries (collectively called “Allison”).
- All consultants, agents, sales representatives, independent contractors, and contract workers (collectively, “Allison Representatives”) when they act on behalf of Allison.

In rare circumstances, a waiver to a particular requirement may be granted by the board of directors and will be promptly disclosed as required by law or regulation. Waivers must be requested and granted in writing. Each salaried employee, director, and officer shall review and acknowledge their understanding on an annual basis.

Throughout our history, Allison has embraced integrity and established it as a core value ensuring it is incorporated in the way our employees conduct business each and every day.

Today, those values and principles are set out in this document, the *Allison Code of Business Conduct* - “Driving Integrity Worldwide.” We believe that integrity is vital to our remaining the world’s largest manufacturer of fully automatic transmissions for medium- and heavy-duty commercial vehicles, medium- and heavy-duty United States defense vehicles and hybrid-propulsion systems for trucks, transit and city buses.

First and foremost, we must act with personal integrity – always keeping in mind our values and guidelines. We must express our concerns when

we believe we have not met the commitments and standards held forth by Allison.

Secondly, it is imperative that we act with integrity on a day-to-day basis in our workplace, being conscientious in treating our co-workers with respect, dignity and fairness. It also requires that we do our part in protecting the health and safety of all employees, using Allison resources responsibly, avoiding conflicts of interest and consistently making decisions that are in the best interest of Allison.

We must conduct ourselves in the global marketplace fairly and honestly, including the many ways in which we interact with our customers, suppliers, dealers and competitors. It will be evident that we’re acting with integrity if we’re dependable in delivering quality products and services, communicating honestly and



meeting our commitments at all levels. To conduct our business with integrity also means we're competing fairly and not allowing our decisions and business judgments to be influenced by personal considerations.

As a company and as individuals, it is imperative that we are complying with applicable laws and regulations, protecting and enhancing the environment and improving the quality of life of individuals through our involvement in our neighborhoods and communities.

In their entirety, these guidelines are designed to provide direction in applying the principles of the Allison values in our day-to-day interactions. They are not intended to address every specific situation encountered. In some cases you will be referred to another document or location for more specific

guidance on a particular subject or policy. If you need assistance in addressing circumstances not covered in this booklet, please consult the supplemental resources summarized at the end of this booklet. As always, ask your direct leadership for guidance if you are unsure about the proper course of action to take when addressing a specific situation.

Outlined in this *Allison Code of Business Conduct* will be information that is relevant to each and every person connected to Allison. However, certain topics will be more applicable than others depending on each person's individual position and responsibilities. It is important that all Allison employees and Allison Representatives familiarize themselves with the standards, beliefs and guidelines that govern the conduct of our fellow team members and Allison as a whole.

PERSONAL INTEGRITY

Personal integrity begins with each of us at Allison Transmission by the decisions and judgments we make as individuals every day. What a person does when no one is watching exemplifies the spirit of personal integrity. Whether our actions are associated with our professional careers or our activities outside of work, our personal behavior, judgment and the decisions we make as individuals define our personal reputations.

To better understand personal integrity, we must examine what it means at its core. At all levels, it conveys that we exemplify the Allison Core Values in our own conduct and that we are complying with Allison policies — even though we may not always fully agree with them.

As part of a global enterprise, differences of opinion about the appropriateness of corporate policies are inevitable. As a company with worldwide operations, Allison recognizes these differences are understandable. However, it is important to comply even when you disagree.

It is essential that we use our sound judgment in determining the precise meaning of Allison values or policies, as well as the intentions and spirit behind them as we make these choices.

Always ask first and act later. If you are unsure of what to do in any situation, seek guidance before you act.

As a corporation, Allison's reputation depends on the actions and decisions of all its employees and Allison Representatives — each and every one of us. There is no doubt that the actions of one person can damage the reputation of all. If anyone compromises the core values or policies of Allison, it is your individual responsibility to take immediate action by either informing the person directly or using other avenues to voice concerns. In most cases, the best option is to discuss the matter with your direct leadership. You can also express your concerns or issues to other experts in the company's Legal, Audit, Security or Human Resources departments.

Another alternative available to everyone globally is the Allison Care Line; this option may provide a measure of anonymity for those who may be uncomfortable openly discussing concerns.

Understanding the Rules

Because laws are complex and changing, good intentions are not always enough to ensure compliance. Everyone whose work is directly affected by particular laws must understand the legal rules well enough to spot problems and know when to get advice. Contact the Allison Legal department with any questions about obligations that may affect your role.

Acting With Integrity When the Rules Seem Unclear

Not all situations are clear cut, so good judgment is essential. Be alert to warning signs. If a questionable proposal is defended as “doing whatever it takes” or because “our competition does it” or “no one will ever know” or “we’ve done it this way before,” chances are it needs to be reconsidered.

When in doubt about the right choice, ask yourself:

Is it legal?

Is it consistent with our core values and policies?

Would you be willing to be accountable for your actions?

Do

Take personal responsibility consistently for performing assignments with Allison policies and all applicable laws and regulations.

Know the rules. Seek guidance from the Legal department or other subject matter experts about laws and regulations relating to your work.

Notify your direct leadership or the Legal department if you have any doubts about whether an action is legal or violates Allison policies.

Don't

Assume it's acceptable to follow instructions that violate the law or Allison policy.

Assume someone else will correct a problem.

Assume a questionable practice is legal just because it has been done by someone else.

INTEGRITY IN THE WORKPLACE

Fair Treatment and Respect

Allison Transmission hires, promotes, trains and pays based on merit, experience or other work-related criteria. Allison values the wide range of backgrounds of our employees. Allison views our diversity as a strength and strives to create work environments that accept and tolerate differences while promoting productivity and teamwork. Each of us is responsible for creating and maintaining a productive work environment where the dignity of all employees is respected.

Equal Employment Opportunity

Allison is committed to equal employment opportunity and extends employment opportunities to all qualified applicants. Allison strives to maintain workplace environments free of discrimination, hostility and physical or verbal harassment with respect to age, race, color, sex, religion, national origin, disability, sexual orientation, gender identity/expression or being a disabled veteran, a veteran of the Vietnam Era or other covered veterans.

Allison employees are entitled to a work environment free from conduct that even appears disrespectful. Certain jokes, cartoons, pictures, language, gestures and touching may offend people and may result in a hostile work environment, which Allison does not tolerate.

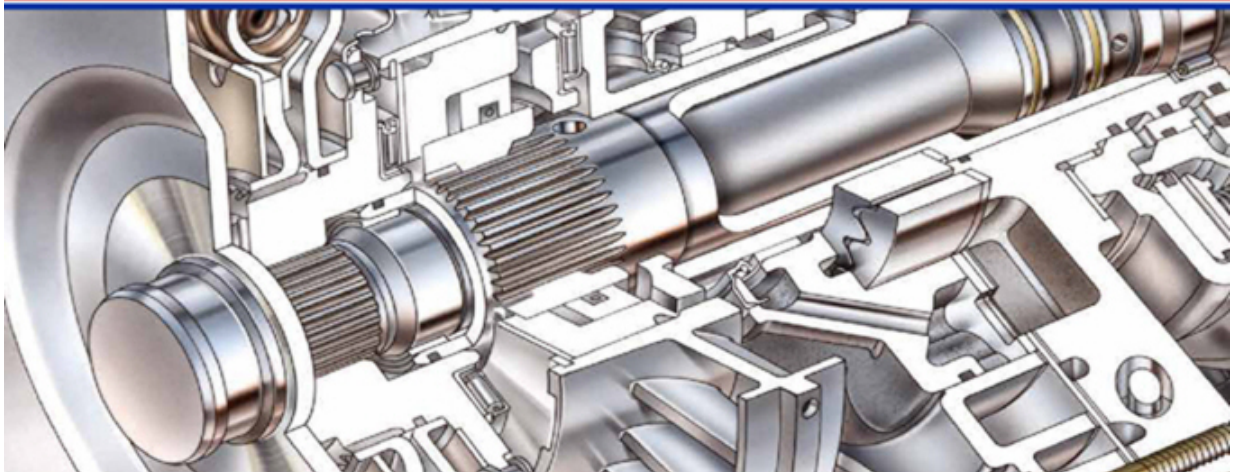

Health and Safety

Allison's overriding priority is to protect the health and safety of each employee. We all have a stake in a healthy, injury-free work environment that protects the health and safety of each employee. We should not compromise any person's well-being in anything we do.

This means following procedures for reducing accident risks and it means using equipment safely. It means following safe workplace practices no exceptions, no shortcuts. It means promptly voicing safety concerns to direct leadership so we can correct situations that may endanger employees. Don't assume that a safety hazard has been reported - take responsibility for reporting it yourself.

Allison encourages employees to continue safe practices outside of the office, such as following safe driving practices: wearing your seatbelt, avoiding distractions (cell phones and texting), not driving while impaired and obeying traffic laws and speed limits.

For more information on Allison Health and Safety policies, please visit the [Global Health and Safety website](#).

Do

Base personnel decisions on merit.

Comply with all applicable workplace health and safety laws, regulations, procedures and Allison's policies.

Always observe safety protocols.

If you must use a phone while driving, use a hands-free device.

Don't

Engage in unsafe workplace activities or create unsafe workplace conditions.

Ignore any unsafe conditions or assume someone else will correct a problem.

Assume that a safety or environmental hazard has been reported; you must take responsibility for reporting it yourself.

Conflicts of Interest

Allison Transmission employees have a responsibility to act solely in the best interests of the company. Avoid any activity, investment or interest that might hurt or reflect badly on Allison. The appearance of a conflict can be just as damaging as an actual conflict of interest. Conflicts of interest are prohibited as a matter of Allison policy, except as approved by the Board of Directors. Conflicts of interest may not always be clear-cut, so if you have a question, you should consult with your direct leadership.

Examples of potential conflicts of interest include:

- Financial interests in a company where you could personally affect Allison's business with that company (i.e. customer, supplier or investment).
- Directing business to suppliers when you know they are owned or managed by your family member or close friends.
- Personal relationships that may conflict with your Allison responsibilities or compromise Allison interests.
- Employment outside Allison without leadership approval.
- Hiring, promoting or directly supervising a family member or close friend.
- Gifts other than of reasonable value from suppliers, customers or competitors that are provided to influence Allison's business decision.

Corporate Opportunities

Employees, directors and officers are prohibited from taking opportunities that are discovered through the use of corporate property, information or position for themselves without the consent of the board of directors. No employee, director, or officer may use corporate property, information or position for personal gain and no employee, director, or officer may compete with Allison directly or indirectly. Employees and officers owe a duty to Allison to advance Allison's interests when the opportunity to do so arises.

Interest in Personal Relationships

If your duties require you to have contact with an organization that employs a relative, former colleague or someone with whom you have a significant personal relationship, including a romantic or sexual relationship, you should take precautions to avoid a potential conflict of interest or even the appearance of preferential treatment.

The organization should receive no advantage or disadvantage because of a personal relationship. When presented with such situations, consult with your direct leadership and, if necessary, step down from acting on behalf of Allison.

Hiring and promotions must not be influenced by a candidate's relationship to any employee, including family, personal, romantic or sexual relationships. If people with such ties are hired or assigned, steps should be taken to avoid any reporting relationship, either direct or indirect, between them. On rare occasions, leadership senior to both of the affected employees may permit a reporting relationship between employees with such ties. Such cases should be reviewed with Allison's General Counsel and Human Resource representatives to ensure no conflict of interest exists in this regard.

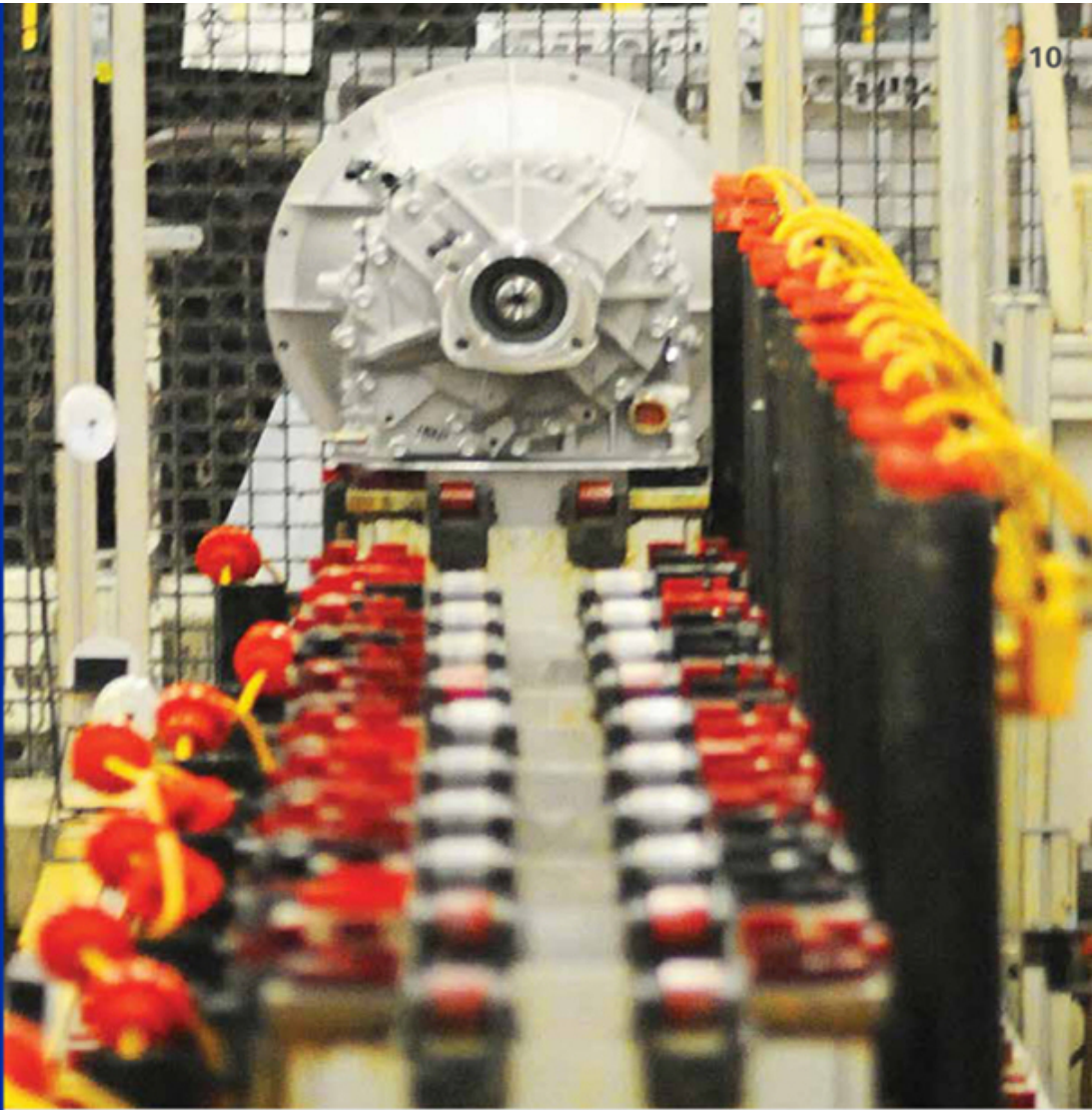

Allison Conflict of Interest Questionnaire

Use the *Allison Conflict of Interest Questionnaire* to disclose any relationships and any other actual or potential conflict of interest. Disclosure lets leaders decide whether an actual conflict exists and how to address it if one does exist.

Allison employees have an ongoing obligation to supplement their *Allison Conflict of Interest Questionnaire* to ensure that they disclose any change in circumstance covered by the questionnaire. In the event such a change occurs, employees should promptly update their conflict of interest disclosure within 30 days.

Interests in Other Businesses

Use the *Allison Conflict of Interest Questionnaire* to disclose certain financial stakes, called a "Material Interest," in a supplier, customer, competitor, etc. For a detailed definition of the type of financial stake that must be disclosed, please refer to the *Conflict of Interest Policy*.

Charitable Activities and Public Service

Allison Transmission applauds service to charities, schools, professional organizations and governmental bodies or advisory groups. Only rarely do conflicts arise from such service. Take the precaution of identifying the organization(s) on your *Allison Conflict of Interest Questionnaire*. When soliciting donations for an outside organization, avoid any impression of pressure by Allison. Donations must be purely voluntary. And do not use Allison letterhead on any solicitation unless Allison supports the fundraising as a corporate activity.

Former Allison Employee Now Supplier Relationships

Allison selects suppliers impartially on the basis of quality, service, technology and price. Allison policy is that former executive and classified employees (retirees or those separated for any reason) who occupied positions prior to termination in which they could influence purchasing decisions should not be received as a representative of a supplier by Allison for a period of two years following their separation. Any exceptions or deviations must be approved and documented by the Legal department and the functional area in which the employee worked prior to separation.



Outside Employment

Outside employment can create conflicts of interest or reduce productivity. Avoid outside business activities that divert time and attention from Allison business. And if any outside activity involves compensation, disclose it to your direct leadership and on the *Allison Conflict of Interest Questionnaire*.

Allison discourages employees from joining boards of outside for-profit companies. Employees may serve on such a board only with prior approval. Never accept any employment by a supplier, customer, dealer or competitor of Allison. When an employee's spouse or partner works for an Allison supplier, customer or competitor, both individuals need to take care to comply with the responsibility each owes to his or her employer.

Do

Each year, each employee should examine his or her personal circumstances as they relate to the *Allison Conflict of Interest Questionnaire* questions to determine if they need to update their disclosure.

Use the *Allison Conflict of Interest Questionnaire* to notify leadership of any potential conflict - even if you think it probably isn't a problem.

Fully disclose any activity, investment, employment or relationship that could create even the appearance of a possible conflict.

Consult the *Conflict of Interest Policy* for advice on how to answer each question.

Keep a copy of the completed *Allison Conflict of Interest Questionnaire* for your own files.

Update your disclosure within 30 days, or any time circumstances covered by the questionnaire change.

Don't

Become involved in any activity, investment, employment or other relationship that could create a conflict with Allison employment.

Fail to fully disclose any activities that could create a conflict or the appearance of a conflict.

Use and Protection of Allison Transmission Assets

Employees and Allison Representatives have an obligation to use and protect Allison's assets in a way that safeguards their value and promotes Allison's business interests. Such assets include financial assets, tangible assets, such as plants, inventory and supplies, information technology related assets, such as computers and software and intangible assets, such as patents and other intellectual property, proprietary information and data. Allison assets should be used for Allison business and in accordance with applicable Allison policies. Furthermore, employees and Allison Representatives have an obligation to use intellectual property and proprietary information belonging to our customers, suppliers and other third parties in accordance with applicable law and any agreements Allison has with such third parties. Each employee and Allison Representative has an obligation to protect information we may receive, acquire, develop or record in performing our jobs. This is not optional – it is absolutely critical that we diligently protect company information.

Accurate Information, Records and Communications

Intentionally creating or inserting false or misleading information in any Allison financial or other business record is strictly prohibited. Inaccurate information may lead to bad decisions by Allison. Allison's customers, suppliers, investors, business partners, communities and government officials rely on us for accurate information.

Allison's books, records, cost accounts and financial statements must properly document all assets and liabilities and must accurately reflect all transactions. All records must be retained in accordance with Allison policy and applicable laws and regulations. Each employee is responsible for ensuring that Allison's business records are accurate, properly recorded and maintained.

Whenever an inaccuracy finds its way into a record, it should be corrected and, where appropriate, the reasons for the correction should be communicated and noted. This is also important in engineering records. An inaccurate record is an "open loop." We need to "close the loop" by clarifying and supplementing the "open loop" record with the accurate data or judgment.

We must also ensure that Allison business records are available to meet the company's business needs, including legal and tax requirements. That's why we must comply with *Allison Information LifeCycle Management (ILM)* policies in creating, managing and disposing of all Allison records. Be alert to and observe litigation holds. These are instructions from the Legal department requiring that certain records sometimes be retained beyond normal retention periods, for legal or compliance reasons. Failure to comply with litigation holds can result in serious harm to Allison, its employees and shareholders. It is unlawful to destroy, conceal, alter or falsify any Allison business or other record, document or object that is subject to a litigation hold or for the purpose of obstructing or influencing any lawsuit or other legal or governmental proceeding or investigation.



“Whenever an inaccuracy finds its way into a record, it should be corrected and, where appropriate, the reasons for the correction should be communicated and noted.”

Use Good Judgment About What You Share And How You Share It

Be honest, truthful and appropriate in everything you do. You are personally responsible for your words and actions, both online and offline. Your posts can potentially tarnish the image, damage the reputation or infringe on the rights of someone else (including Allison Transmission and its employees). Even comments about a local topic can spread around the globe in an instant.

Company Vehicles

Employees may use Allison owned vehicles only as authorized by management. Employees must operate Allison owned vehicles lawfully and must comply with Allison policies applicable to company vehicles in the location where the vehicle is operated.

Internet/Email and Voice Mail

As a rule, use the Internet only for work assignments. Nominal personal use is permitted if it does not interfere with work or productivity and does not conflict with directions from your direct leadership or with *Allison's Acceptable Use Practices*. If in doubt, ask your direct leadership.

All messages transmitted on Allison's email and voice mail systems and activity on Allison's computer systems become records of Allison. No employee should expect that they will be treated as personal or private messages. Allison can and sometimes does, access or monitor its email, internet, voice mail and other computer systems for legitimate business reasons. Allison may delete any email or voice mail messages or disclose them to others, without advance notice, unless applicable law provides differently.

Be Clear That The Views You Are Expressing Are Your Own

Only persons who have been authorized can speak on behalf of Allison in an official capacity. Transparency is important in social media. Posting anonymously online should be avoided. Make sure that, even when you have identified yourself as working for Allison (including on your social media profiles like Twitter, LinkedIn or Facebook), you are clear that your views and opinions are your own and not those of Allison. If you think an "official" Allison response may be required, contact the Allison Government and Community Relations department.

Be Aware That Online Communications Travel Fast, Remain Forever And Are Usually NOT "Private"

There are no secrets on the Internet. Information you may think you have protected as "private" on some social media sites may be accessed by others. Make sure you will have no regrets about what you said or did online if a reporter, a relative or your manager were to view it.

If you are still unclear what actions are considered to be a violation of Allison policy, please ask.

Whether you are using email, voice mail or social media channels, never make any illegal, unethical, unauthorized or disruptive use of Allison information systems or equipment. This includes accessing, transmitting or storing inappropriate material (e.g., pornography, depicted nudity, lewd or violent materials, chain letters, sexually oriented jokes or cartoons or other offensive/demeaning material related to age, race, color, sex, religion,

national origin, disability or sexual orientation).
Violations will subject you to disciplinary action up to
and including termination.

If you get an inappropriate message or are
confronted with instances of unethical business
practices or behavior, report it to your direct
leadership or contact the Allison Care Line.

**“Be honest, truthful
and appropriate in
everything you do.
You are personally
responsible for your
words and actions,
both online and
offline.”**



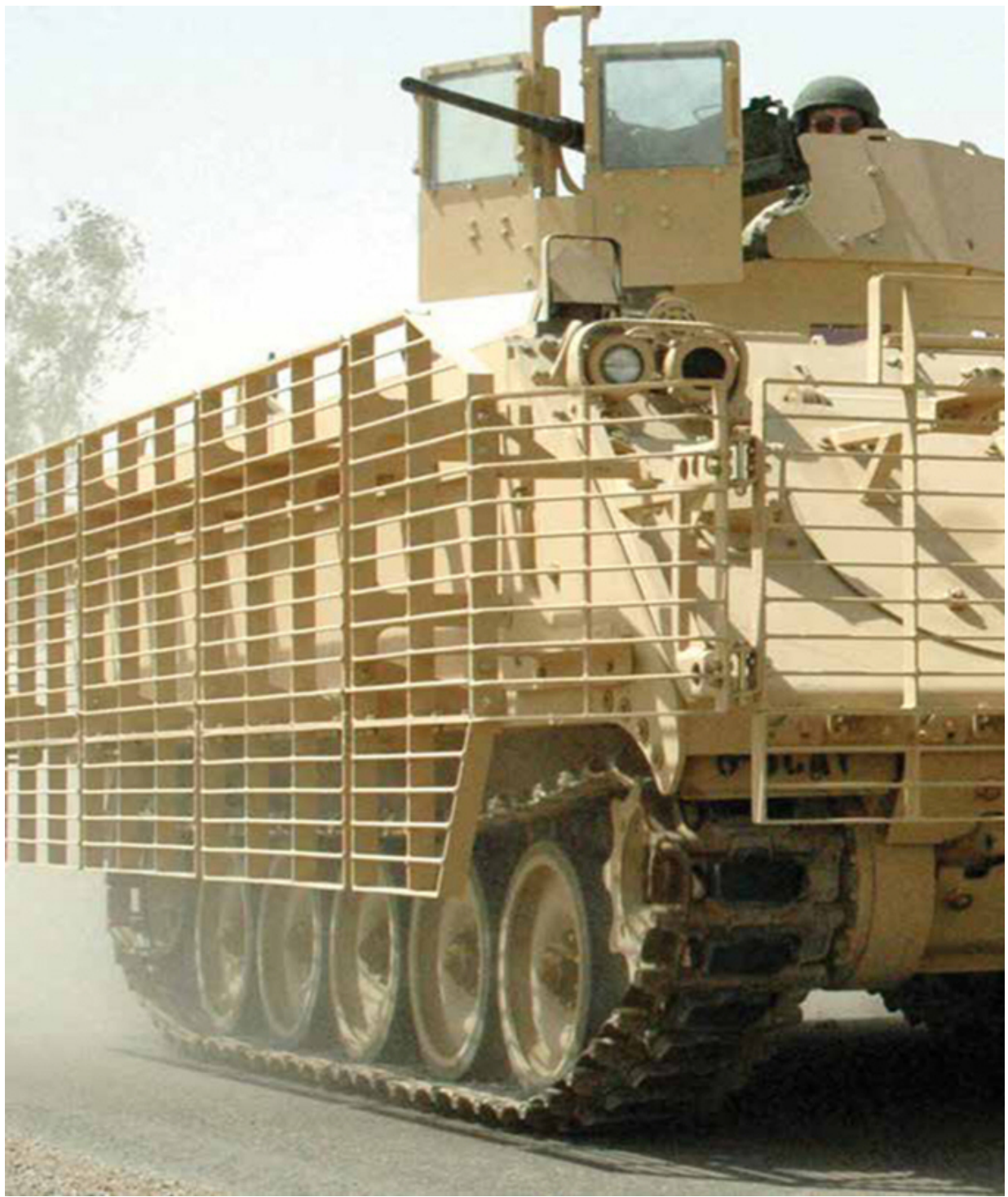

Communicating with the Media

The Allison Transmission Government and Community Relations staff is responsible for all communications with the press or the media related to Allison business by Allison and by all Allison employees, globally. The rule to follow here is simple. Unless approved by an appropriate member of Allison, you are not authorized to speak with any representative of the press or media regarding Allison business. If a media representative contacts you, do not answer any questions or make any statements. You should direct them to the Allison Government and Community Relations department and immediately notify your direct leadership. Failure to follow this simple rule can result in disciplinary action up to and including termination. Please consult Allison's *Regulation Fair Disclosure Policy* for further information.

Protecting Allison Information

Each employee and Allison Representative has an obligation to protect information we may receive, acquire, develop or record in performing our jobs. This is not optional – it is absolutely critical that we diligently protect company information.

What does this mean?

- Only access information you need and are authorized to view.
- Communicate confidential information only to Allison employees and authorized agents (such as attorneys, auditors, accountants) who have a legitimate business reason to know the information.
- Do not display, review or discuss Allison information in public places, with third parties or in areas where others may hear you.

- Only in extenuating circumstances should you email Allison information to your personal email account or otherwise remove information from Allison, whether in hard copy or using any form of media device to record. Be mindful that any personal accounts or devices utilized will become subject to litigation holds and discovery.
- Never disclose Allison information without the prior approval of senior management.
- Be aware of Allison's policies on communicating with third parties. Please consult Allison's *Regulation Fair Disclosure Policy* and *Insider Trading Policy* for further information.

Information may include product plans, vehicle designs, strategy documents, communications to and from Allison management and the Board of Directors, prospective business opportunities, pricing information, financial or technical data or a planned meeting between an Allison leader and an outside party.

All Allison information belongs to Allison, not to Allison employees, regardless of the nature, medium or form of the information.

Your ongoing obligation to protect Allison information continues even if you leave Allison. You must return all information in your possession or control if you leave and if requested, sign a statement confirming your compliance with respect to the information. Also, do not bring any confidential information from a previous employer to Allison, unless there is an agreement otherwise executed by your previous employer and Allison. The company will take whatever steps are necessary to ensure Allison information is protected.

Litigation and Investigations

Litigation is a fact of life. Requests for documents in various forms (paper, email, etc.) related to litigation and other legal proceedings normally flow through channels set up for that purpose, but there may be times when other employees receive them. Consult immediately with the Legal department if, as a representative of Allison Transmission, you receive any summons, subpoena, inquiry or other communication from a court, marshal, sheriff, government agency or from any lawyer. Before submitting to an interview, answering any questions, producing any documents or even responding to any questions about litigation or an investigation, consult with the Legal department. This applies to matters in which Allison is involved directly, like an investigation or a lawsuit involving an Allison product or an Allison facility. It also applies to matters in which Allison is involved indirectly, including investigations of suppliers, dealers or competitors.

Do

Know and comply with the *Allison Information Security Policy and Practices* and *Information LifeCycle Management Policies*.

Treat all Allison information and property as valuable business assets belonging to someone else - Allison shareholders.

Make sure communications are accurate - whether internal or external.

Comply with all applicable laws and regulations and *Allison Acceptable Use Practices* governing the use of Allison information resources such as computers, software, email, the Internet and intranet.

Don't

Ignore security procedures to save time.

Give access to Allison information to anyone not authorized to have it.

Use Allison property or systems for your own personal profit or gain or for personal activity.

Create or knowingly process misleading or inaccurate information about Allison business.

Use Allison information resources to create, access, transmit or store any material that is in bad taste, offensive, disrespectful of others or otherwise inappropriate.

Do anything that would disrupt or compromise the availability, integrity or security of Allison information, information resources or other Allison property.

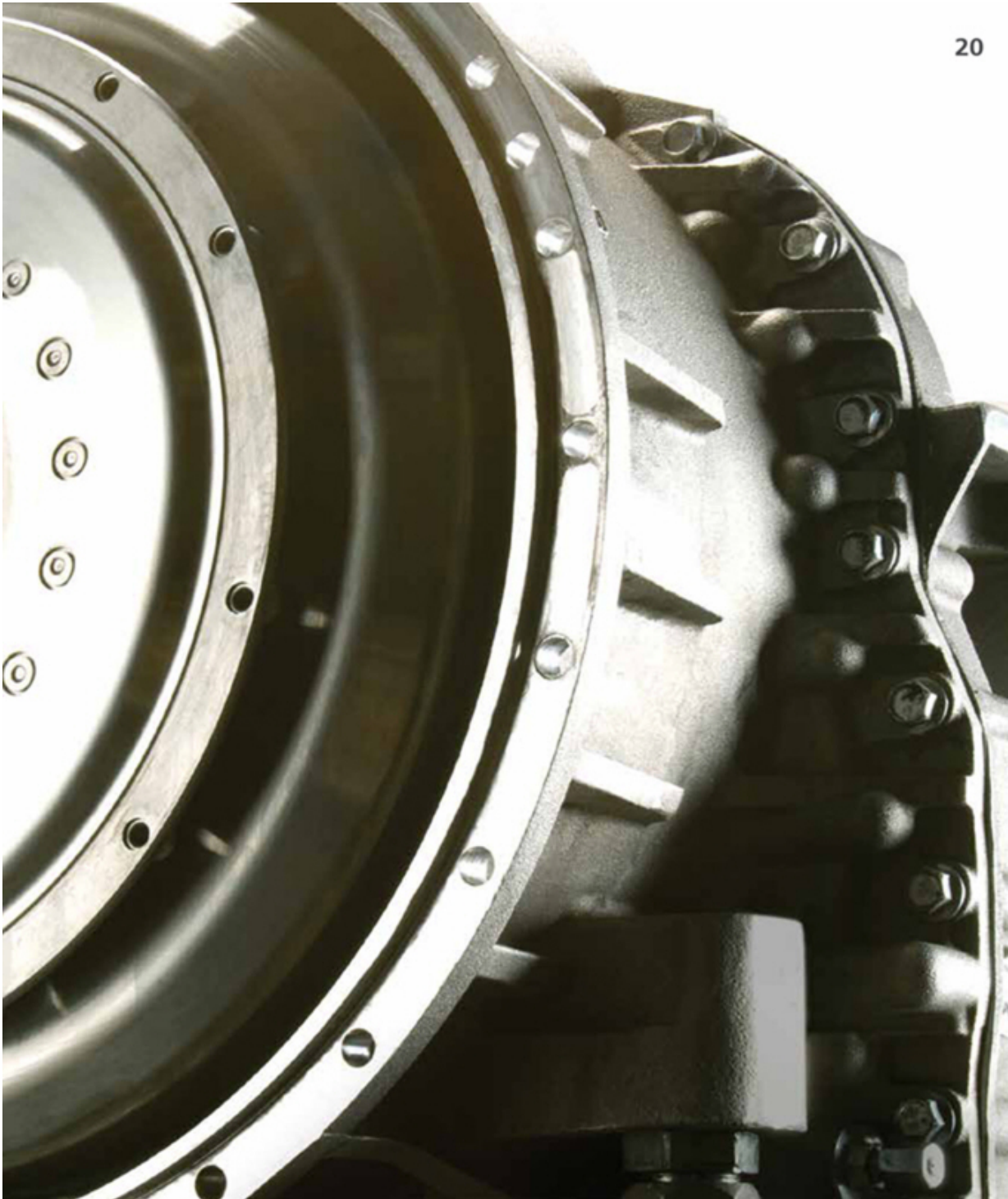

INTEGRITY IN THE MARKETPLACE

Fair Competition

Allison Transmission is committed to competing within the law. This section discusses the laws that protect or regulate the competitive process. These laws can be complicated and they vary from country to country. So, when in doubt, consult the Legal department.

Gifts, Entertainment and Gratuities

Gifts, gratuities and entertainment are courtesies often designed to build relationships. In a business setting, however, ethical problems can arise when these items compromise or appear to compromise our ability to make impartial, objective and fair business decisions. The *Allison Global Third Party Gifts and Entertainment Policy* and the applicable reporting procedures are intended to guide our judgment when confronted with opportunities to accept or give certain gifts, gratuities or entertainment from or to suppliers, dealers, customers or other third parties. For more information please see the *Allison Global Third Party Gifts and Entertainment Policy* and the applicable reporting procedures.

Relations With Competitors

One rule is crystal-clear: Never agree with a competitor on any element of price (including, for example, discounts, rebates or incentives) or on what products to develop or to whom we sell. And "agree" doesn't necessarily mean having a written contract. Courts sometimes find an illegal agreement based on a conversation, even if the conversation occurred on a golf course or another semi-private location.

- Benchmarking with a competitor may be risky, so get legal and business approval before doing it.
- Competitive analysis is vital to Allison, but don't exchange competitive information directly with competitors. Customers, suppliers or experts may be able to provide marketplace intelligence.
- Avoid discussing sensitive topics like price, costs or marketing plans at trade association meetings.

“Allison is committed to competing within the law.”

Relations With Dealers, Distributors and Resellers

It is against Allison policy and illegal in most countries, to force any dealer, distributor or retailer to sell at a particular price. We can set a suggested retail price, but each dealer must remain free to set the sale price with customers. Consult the Legal department if you have questions about a non-price restriction.

International Consideration

U.S. antitrust laws apply to activity that hurts the competitive process in the U.S. so actions by Allison subsidiaries around the world could be challenged by U.S. authorities. Most countries around the world also have their own competition laws.



Insider Trading

In the course of our work, we may acquire important information about Allison Transmission or other companies, which has not yet become publicly available. Never trade in Allison securities or those of any other company while in possession of material, nonpublic information. Material information is any information that an investor would reasonably consider important in making investment decisions. Examples include knowledge of acquisitions or divestitures, new product launches, financial information, production schedules or management changes. These situations are fact and circumstances specific so consult with the Legal department.

If you learn something that could reasonably be expected to affect the price of Allison stock (or the stock of another company), do not buy or sell the stock – or disclose the information to others – until the information has been released to the public. Anytime you trade in Allison stock you must make sure the trading window is open.

For any questions on Allison's Insider Trading Policy, contact the Legal department.

Do

Read and understand *Allison's Insider Trading Policy* before trading in Allison securities.

If the nature of your position and business activities subjects you to additional requirements relating to transacting in Allison stock, consult the Legal department and learn and follow any additional requirements.

Don't

Share material, nonpublic information about any company with anyone who might trade that company's securities.

Assume insider trading rules only apply to trading in Allison stock.

Trade when the trading window is closed.

Discuss Allison business with family and friends.

Talk about what you're working on or where you're going on company business or who is visiting Allison.

Buy or sell the securities of any company, including Allison, either directly or through family members or other persons or entities, while you are aware of inside information about the company. (This is known as insider "trading" and is illegal.)

Recommend or suggest that anyone else buy or sell the securities of any company, including Allison, while you have inside information about the company. (This is known as "tipping" and is illegal.)



INTEGRITY IN OUR SOCIETIES AND COMMUNITIES

Conflicts with Laws

Allison Transmission conducts business in more than 100 countries around the globe and our employees are citizens of many different countries. As a result, our business is subject to the laws of many different countries, provinces, states and municipalities and organizations such as the European Union.

An important challenge for all of us is to understand these laws and how they may apply to our business. Allison is a corporation organized under the laws of the U.S. These U.S. laws regularly extend to the business activities of Allison and its affiliates throughout the world, as well as to the business activities of Allison employees and Allison Representatives globally. Other countries may also apply their laws and regulations outside of their nation's borders to their own residents and to organizations that are organized under their laws, such as Allison subsidiaries or other controlled entities.

The references in Allison policies to the laws of the U.S. and the other locations where we do business reflect the reality that a global company is regulated by several different laws at the same time. In some instances, there may be a conflict between the applicable laws of two or more countries. If you encounter such a conflict, it is especially important to consult the Allison Legal department to understand how to resolve the situation properly.

Improper Gifts and Payments

An improper gift or payment to gain advantage in any situation is unacceptable and exposes you and Allison to possible criminal and civil prosecution. Allison policy expressly prohibits improper payments in all business dealings, in every country worldwide, with both governments and the private sector, even if it may be seen as "customary in some countries."

Improper gifts and payments should not be confused with reasonable and limited expenditures for gifts, business entertainment and customer travel directly related to the promotion of products or services or the execution of a contract. These payments are acceptable, subject to specific Allison corporate and business guidelines.

The *Allison Global Anticorruption Compliance Policy* applies to all employees, Allison Representatives and its controlled affiliates, whether in the U.S. or outside the U.S.

For additional information about requirements in this area, please contact the Legal department. If you believe that you may have provided an improper gift to a government official, it is important that you contact the Legal department immediately.

Do

Consult with the Legal department to understand Allison anticorruption requirements.

Contact management or the Legal department if a government official solicits something of value.

Make sure, before hiring a representative to arrange business for Allison, that the representative is informed about U.S. law and Allison policy restrictions on payments to foreign officials.

Make sure you understand applicable legal requirements, the customer's own rules and Allison corporate and business guidelines before giving a gift, providing customer entertainment or reimbursing customer travel expenses.

Make sure records of any expenditure are accurately recorded to reflect the true nature of the transaction.

Require any person or firm who is an Allison Representative to comply with this policy and related laws.

Follow the Allison due diligence procedures when selecting Allison Representatives.

Don't

Offer a business courtesy, such as a political or charitable contribution or entertainment, under circumstances that might create the appearance of impropriety.

Assume a practice is acceptable because another company reportedly has done it or it has been done in the past.

Assume a potential representative or agent will know the law or Allison expectations in this area – discuss it before entering a relationship.

Offer, promise, pay or authorize anything of value (money, goods or services) to a government official or employee of a customer to obtain or retain business. You can never buy the business.

Contribute Allison funds or other Allison assets for political purposes without the prior written approval of the Managing Director for Government and Community Relations.

Export Compliance

Several U.S. laws and regulations govern how we conduct certain transactions with foreign countries and specific parties. These laws apply not only to U.S. operations, but also to U.S. persons, wherever they are located, and products manufactured around the world using U.S.-origin parts or technology. Other countries have similar laws.

“‘Export’ means not only shipping an item outside the country, but also sharing data with a foreign person inside the country.”

Export Controls

The law requires an export license before certain categories of products or data can be exported or re-exported. “Export” means not only shipping an item outside the country, but also sharing data with a foreign person inside the country. Examples of products requiring export licenses are numerically controlled machines, night vision equipment, computers, military products, software and related technical data.

If you have knowledge or even suspicion that a transaction may involve a violation of export regulations, immediately report it to the Allison Transmission Office of Export Compliance or your business unit Export Compliance Officer. Be alert to a “red flag” indicating that a transaction may not be what it seems. For example, the product’s characteristics may not fit the buyer’s business or the buyer may be reluctant to offer information about the product’s intended end use. When in doubt, don’t enter into the transaction.



Foreign Asset Controls

Foreign asset controls are economic sanctions or embargoes the U.S. places on certain countries or groups to motivate them to change certain practices. These controls apply to U.S. citizens, residents, companies and sometimes to international subsidiaries of U.S. companies. The rules vary, but they tend to be broad.

Employees must get guidance from the Allison Office of Export Compliance before dealing with a sanctioned country or entity. Currently, the U.S. has imposed broad based sanctions against Cuba, Iran, North Korea, Sudan and Syria. A complete list of sanctioned countries and entities can be found at the Allison Office of Export Compliance website under Embargoed Countries.

Anti-boycott Regulations

U.S. anti-boycott laws and regulations prohibit participating in foreign boycotts that are unsanctioned by the U.S. These regulations apply to U.S. companies, their domestic and foreign controlled subsidiaries and U.S. persons. Prohibited acts include refusing to do business with a country or with a company in a country, or requiring anyone else to refuse to do business at the request of a boycotting country or business. They also prohibit supplying information about the religion, sex or nationality of an employee or supplier, as well as doing anything that would support an unsanctioned boycott of a country friendly to the U.S.

If you receive any request to take any of these actions, contact the Allison Office of Export Compliance immediately.



INTEGRITY TOWARD THE ENVIRONMENT

Allison Transmission Environmental Principles

As a responsible corporate citizen, Allison is committed to protecting human health, natural resources and the global environment. First and foremost, Allison operating units are responsible for understanding and complying with applicable environmental laws, regulations and Allison policies and standards. This commitment reaches further than compliance with the law to encompass the integration of sound environmental practices into our business decisions.

The following *Allison Environmental Principles* provide guidance to Allison personnel worldwide:

- We are committed to actions to restore and preserve the environment.
- We are committed to reducing waste and pollutants, conserving resources and recycling materials at every stage of the product life cycle.
- We will continue to pursue vigorously the development and implementation of technologies for minimizing pollutant emissions and improving fuel economy.
- We will continuously assess the impact of our plants and products on the environment and the communities in which we live and operate with a goal of continuous improvement.



Compliance With the Law

For more information about Allison policies relating to environmental matters, see the Allison intranet.

Do

Become familiar with Allison's Environmental Principles and Policies.

Report to leadership any incident or practice inconsistent with our *Environmental Principles and Policies*.

Don't

Assume environmental issues are the concern only of the experts.

Ignore any practice you see that violates the law or Allison policies.

Fail to address with appropriate leadership any inaccurate report on an environmental issue.



CONCLUSIONS

We strive to act with personal and institutional integrity in the workplace, the marketplace and the communities where we live. We must all understand and apply our values and policies to ensure that we compete fairly and maintain our status as a global symbol of excellence. "Driving Integrity Worldwide" poses a challenge to each of us. It requires strength of character to act when the easier course would be to ignore the problem.

We can all fulfill our responsibilities by:

- Following "Driving Integrity Worldwide", *Allison Transmission's Code of Business Conduct*.
- Speaking out and raising potential instances of misconduct to leadership.
- Giving feedback on problem areas and suggesting improvements to leadership.
- Listening to the concerns of customers, co-workers, dealers and suppliers – and making sure this information gets proper attention.
- Conducting ourselves with the highest ethical standards.

Employees who violate this policy are subject to disciplinary action that, in the judgment of management, is appropriate to the nature of the violation, which may include termination of employment. Employees may also be subject to civil and criminal penalties if the law has been violated.



At the same time, it is important that everyone feel confident they can speak up and report a concern or violation of the *Allison Code of Business Conduct* without fear of retaliation and that the concerns or violations will be fully investigated in a timely manner.

Allison has established the *Allison Whistleblower Policy* safeguarding employees from retaliations for reporting suspected concerns or violations of the *Allison Code of Business Conduct*. Allison has also established several ways for reporting concerns, including anonymous reporting via the Allison Care Line where allowed by law.

“We strive to act with personal and institutional integrity in the workplace, the marketplace and the communities where we live.”



Resources and Contact Information:

CORPORATE POLICIES

Corporate Policies are located on Process Central

ALLISON CARE LINE

Anonymous reports can be made via email to aticare@wackenhut.g4s.com, through the internet to <http://aticare.safe2say.info/> or for calls originating in the U.S. or Canada 1-866-296-8176; for calls originating from foreign countries please check below.

Canada (866) 296 8176	Brazil 0800 891 5325	Hungary 06 800 16703	Netherlands 0800 0222 316	Russia Access # - 8*10 800
Argentina 0800 666 3627	China (North) 10800 713 1339	India 000 800 100 3528	Singapore 800 1301 695	110 2011 (Rostelecom)
Australia 1800 051 651	China (South) 10800 130 1296	Japan 005131 13 1410	South Africa 0800 981 588	OR Access # - 747 3324 (Rostelecom ASVT.
Austria Access# - 0800 200 236 + 866296-8176	France 0800 912 279	Korea 00308 132 163	Sweden 020 796 520	Outside of Moscow dial 8095 before number. Local charges apply)
	Germany 0800 181 4475	Mexico 001 866 296 8176	United Kingdom 0808 101 2237	AND + 8662968176

HUMAN RESOURCES

For Human Resources questions, please contact your local Human Resources leader. If you are not able to contact your local Human Resources leader, you can call

**Mary Anne Hoffman, Managing Director,
Human Resources**

Tel: U.S. 317-242-2311

Email: MaryAnne.Hoffman@allisontransmission.com

GOVERNMENT AND COMMUNITY RELATIONS

**Melissa Sauer, Managing Director, Government
and Community Relations**

Tel: U.S. 317-242-3855

Email: melissa.sauer@allisontransmission.com

INTERNAL AUDIT

Scott Smale, Director, Internal Audit

Tel: U.S. 317-242-2015

Email: scott.smale@allisontransmission.com

LEGAL DEPARTMENT

Travis Bonnell, Chief Compliance Officer

Tel: U.S. 317-242-3113

Email: travis.bonnell@allisontransmission.com

Eric Scroggins, VP and General Counsel

Tel: U.S. 317-242-7017

Email: eric.scroggins@allisontransmission.com

INVESTOR RELATIONS

Tel: U.S. 317-242-3078

Email: ir@allisontransmission.com

ALLISON GLOBAL HEADQUARTERS

One Allison Way

Indianapolis, IN

46222-5200

United States of America

Tel: U.S. 317-242-5000

List of Subsidiaries*

NameState or Country of
Organization

Allison Transmission, Inc.

Delaware

* Omits names of subsidiaries that as of December 31, 2014 were not, in the aggregate, a "significant subsidiary."

CONSENT OF INDEPENDENT REGISTERED PUBLIC ACCOUNTING FIRM

We hereby consent to the incorporation by reference in the Registration Statements on Form S-8 (No. 333-180285) and on Form S-3 (No. 333-187903) of Allison Transmission Holdings, Inc. of our report dated February 20, 2015 relating to the financial statements, financial statement schedule and the effectiveness of internal control over financial reporting, which appears in this Form 10-K.

/s/ PricewaterhouseCoopers LLP
Indianapolis, Indiana
February 20, 2015

**CERTIFICATION PURSUANT TO RULE 13a-14(a)/15d-14(a) OF THE SECURITIES
EXCHANGE ACT OF 1934, AS ADOPTED PURSUANT TO SECTION 302 OF THE
SARBANES-OXLEY ACT OF 2002**

I, Lawrence E. Dewey, certify that:

1. I have reviewed this annual report on Form 10-K of Allison Transmission Holdings, Inc.;
2. Based on my knowledge, this report does not contain any untrue statement of a material fact or omit to state a material fact necessary to make the statements made, in light of the circumstances under which such statements were made, not misleading with respect to the period covered by this report;
3. Based on my knowledge, the financial statements, and other financial information included in this report, fairly present in all material respects the financial condition, results of operations and cash flows of the registrant as of, and for, the periods presented in this report;
4. The registrant's other certifying officer and I are responsible for establishing and maintaining disclosure controls and procedures (as defined in Exchange Act Rules 13a-15(e) and 15d-15(e)) and internal control over financial reporting (as defined in Exchange Act Rules 13a-15(f) and 15d-15(f)) for the registrant and have:
 - a) designed such disclosure controls and procedures, or caused such disclosure controls and procedures to be designed under our supervision, to ensure that material information relating to the registrant, including its consolidated subsidiaries, is made known to us by others within those entities, particularly during the period in which this report is being prepared;
 - b) designed such internal control over financial reporting, or caused such internal control over financial reporting to be designed under our supervision, to provide reasonable assurance regarding the reliability of financial reporting and the preparation of financial statements for external purposes in accordance with generally accepted accounting principles;
 - c) evaluated the effectiveness of the registrant's disclosure controls and procedures and presented in this report our conclusions about the effectiveness of the disclosure controls and procedures, as of the end of the period covered by this report based on such evaluation; and
 - d) disclosed in this report any change in the registrant's internal control over financial reporting that occurred during the registrant's most recent fiscal quarter (the registrant's fourth fiscal quarter in the case of an annual report) that has materially affected, or is reasonably likely to materially affect, the registrant's internal control over financial reporting; and
5. The registrant's other certifying officer and I have disclosed, based on our most recent evaluation of internal control over financial reporting, to the registrant's auditors and the audit committee of the registrant's board of directors (or persons performing the equivalent functions):
 - a) all significant deficiencies and material weaknesses in the design or operation of internal control over financial reporting which are reasonably likely to adversely affect the registrant's ability to record, process, summarize and report financial information; and
 - b) any fraud, whether or not material, that involves management or other employees who have a significant role in the registrant's internal control over financial reporting.

Dated: February 20, 2015

/s/ Lawrence E. Dewey

Name: Lawrence E. Dewey

Title: Chairman, President and Chief Executive Officer
(Principal Executive Officer)

**CERTIFICATION PURSUANT TO RULE 13a-14(a)/15d-14(a) OF THE SECURITIES
EXCHANGE ACT OF 1934, AS ADOPTED PURSUANT TO SECTION 302 OF THE
SARBANES-OXLEY ACT OF 2002**

I, David S. Graziosi, certify that:

1. I have reviewed this annual report on Form 10-K of Allison Transmission Holdings, Inc.;
2. Based on my knowledge, this report does not contain any untrue statement of a material fact or omit to state a material fact necessary to make the statements made, in light of the circumstances under which such statements were made, not misleading with respect to the period covered by this report;
3. Based on my knowledge, the financial statements, and other financial information included in this report, fairly present in all material respects the financial condition, results of operations and cash flows of the registrant as of, and for, the periods presented in this report;
4. The registrant's other certifying officer and I are responsible for establishing and maintaining disclosure controls and procedures (as defined in Exchange Act Rules 13a-15(e) and 15d-15(e)) and internal control over financial reporting (as defined in Exchange Act Rules 13a-15(f) and 15d-15(f)) for the registrant and have:
 - a) designed such disclosure controls and procedures, or caused such disclosure controls and procedures to be designed under our supervision, to ensure that material information relating to the registrant, including its consolidated subsidiaries, is made known to us by others within those entities, particularly during the period in which this report is being prepared;
 - b) designed such internal control over financial reporting, or caused such internal control over financial reporting to be designed under our supervision, to provide reasonable assurance regarding the reliability of financial reporting and the preparation of financial statements for external purposes in accordance with generally accepted accounting principles;
 - c) evaluated the effectiveness of the registrant's disclosure controls and procedures and presented in this report our conclusions about the effectiveness of the disclosure controls and procedures, as of the end of the period covered by this report based on such evaluation; and
 - d) disclosed in this report any change in the registrant's internal control over financial reporting that occurred during the registrant's most recent fiscal quarter (the registrant's fourth fiscal quarter in the case of an annual report) that has materially affected, or is reasonably likely to materially affect, the registrant's internal control over financial reporting; and
5. The registrant's other certifying officer and I have disclosed, based on our most recent evaluation of internal control over financial reporting, to the registrant's auditors and the audit committee of the registrant's board of directors (or persons performing the equivalent functions):
 - a) all significant deficiencies and material weaknesses in the design or operation of internal control over financial reporting which are reasonably likely to adversely affect the registrant's ability to record, process, summarize and report financial information; and
 - b) any fraud, whether or not material, that involves management or other employees who have a significant role in the registrant's internal control over financial reporting.

Dated: February 20, 2015

/s/ David S. Graziosi

Name: David S. Graziosi
Title: Executive Vice President, Chief Financial Officer and
Treasurer (Principal Financial Officer)

**CERTIFICATION PURSUANT TO
18 U.S.C. SECTION 1350,
AS ADOPTED PURSUANT TO
SECTION 906 OF THE SARBANES-OXLEY ACT OF 2002**

In connection with the Annual Report of Allison Transmission Holdings, Inc. (the "Company") on Form 10-K for the fiscal year ended December 31, 2014 as filed with the Securities and Exchange Commission on the date hereof (the "Report"), we, Lawrence E. Dewey, Chairman, President and Chief Executive Officer of the Company, and David S. Graziosi, Executive Vice President, Chief Financial Officer and Treasurer of the Company, certify, pursuant to 18 U.S.C. §1350 as adopted pursuant to §906 of the Sarbanes-Oxley Act of 2002, that:

1. The Report fully complies with the requirements of Section 13(a) or 15(d) of the Securities Exchange Act of 1934; and
2. The information contained in the Report fairly presents, in all material respects, the financial condition and results of operations of the Company.

Dated: February 20, 2015

/s/ Lawrence E. Dewey

Lawrence E. Dewey
Chairman, President and Chief Executive Officer (Principal
Executive Officer)

Dated: February 20, 2015

/s/ David S. Graziosi

David S. Graziosi
Executive Vice President, Chief Financial Officer and
Treasurer (Principal Financial Officer)